

## **Planning and Setup Guide**

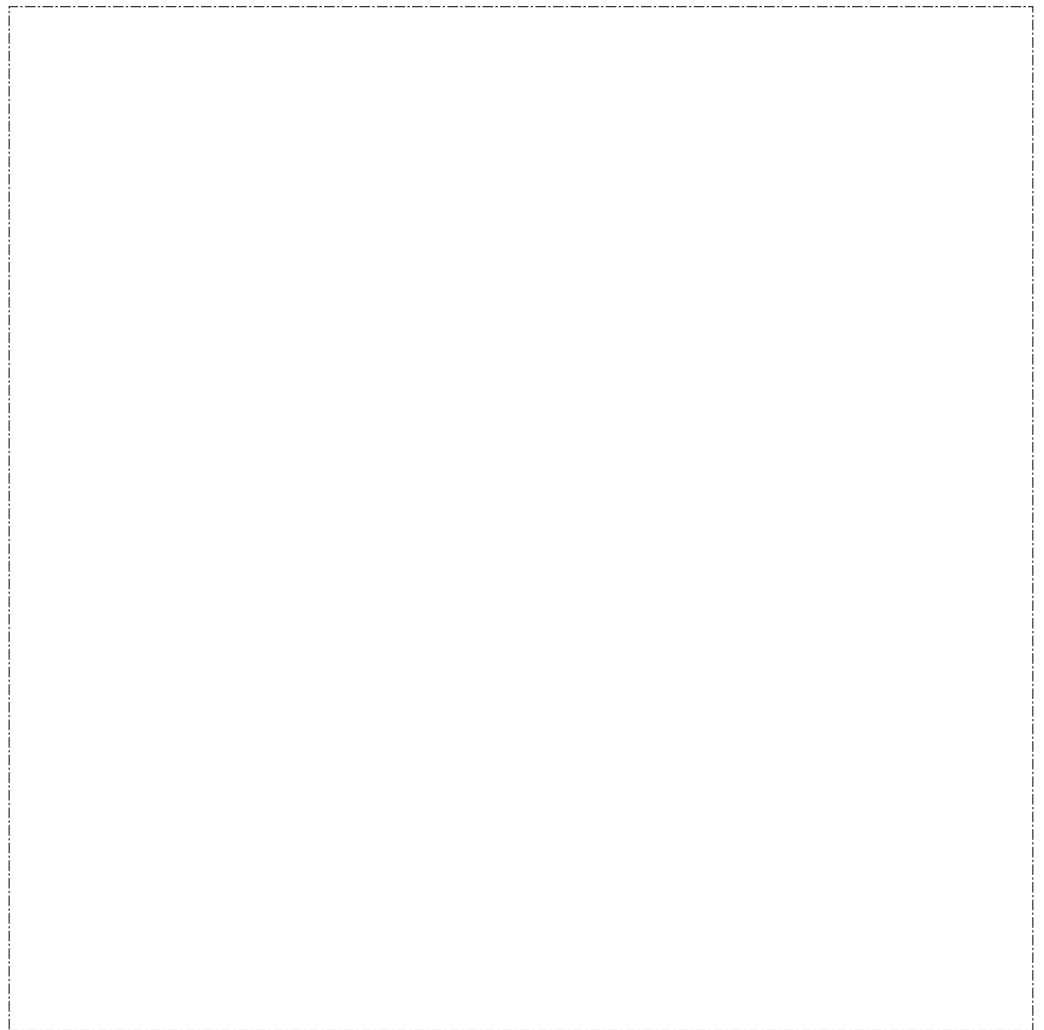





2216 Nways Multiaccess Connector

GA27-4105-00

## **Planning and Setup Guide**

**Note**

Before using this information and the product it supports, be sure to read the general information under Appendix F, "Notices" on page F-1.

**First Edition (March 1997)**

This edition applies to the IBM 2216 Nways Multiaccess Connector Model 400.

Order publications through your IBM representative or the IBM branch office serving your locality. Publications are not stocked at the address given below.

Forms for readers' comments appear at the front and back of this publication. If the forms have been removed, address your comments to:

Department CGF  
Design & Information Development  
IBM Corporation  
PO Box 12195  
RESEARCH TRIANGLE PARK NC 27709-9990  
USA

When you send information to IBM, you grant IBM a nonexclusive right to use or distribute the information in any way it believes appropriate without incurring any obligation to you.

© **Copyright International Business Machines Corporation 1997. All rights reserved.**

Note to U.S. Government Users — Documentation related to restricted rights — Use, duplication or disclosure is subject to restrictions set forth in GSA ADP Schedule Contract with IBM Corp.

---

# Contents

<b>About This Manual</b> . . . . .	ix
Who Should Read This Manual . . . . .	ix
How This Manual Is Organized . . . . .	ix
How Do I Proceed? . . . . .	x
Library Overview . . . . .	xii
<b>Chapter 1. Introduction</b> . . . . .	1-1
IBM 2216 Highlights . . . . .	1-2
Additional Technical Details . . . . .	1-2
Benefits . . . . .	1-4
Hardware Ordering Information . . . . .	1-4
<b>Chapter 2. Planning and Technical Details</b> . . . . .	2-1
Networks Supported by the IBM 2216 . . . . .	2-1
Protocols Supported by the IBM 2216 . . . . .	2-2
Features Supported . . . . .	2-2
Options . . . . .	2-3
2-port Token-Ring (FC 2280) . . . . .	2-3
2-port Ethernet (FC 2281) . . . . .	2-3
8-port EIA-232E/V.24 Adapter (FC 2282) . . . . .	2-3
1-port ISDN PRI (T1/J1) Adapter (FC 2283) . . . . .	2-3
1-port ATM 155-Mbps Multimode Fiber Adapter (FC 2284) . . . . .	2-4
6-Port V.35/V.36 Adapter (FC 2290) . . . . .	2-4
8-Port X.21 Adapter (FC 2291) . . . . .	2-4
1-port ISDN PRI (E1) Adapter (FC 2292) . . . . .	2-5
1-port ATM 155-Mbps Single-Mode Fiber Adapter (FC 2293) . . . . .	2-5
Cables . . . . .	2-5
Slots and Adapters . . . . .	2-8
Factory Plugging Defaults . . . . .	2-8
Placement Options . . . . .	2-8
Tabletop . . . . .	2-8
Rack . . . . .	2-8
Preparing the Machine Area . . . . .	2-9
Access to the Unit . . . . .	2-9
Physical Specifications . . . . .	2-9
Weight . . . . .	2-9
Service Clearances . . . . .	2-9
Airflow . . . . .	2-9
Environment . . . . .	2-10
Lightning Protection . . . . .	2-10
Electromagnetic Interference . . . . .	2-10
Power Supply . . . . .	2-10
Power Supply Requirements . . . . .	2-10
Power Cord Characteristics . . . . .	2-10
Hardware Requirements . . . . .	2-12
Hardware and Software Requirements for the Configuration Program . . . . .	2-13
<b>Chapter 3. Accessing and Managing the IBM 2216</b> . . . . .	3-1
Accessing the IBM 2216 . . . . .	3-1
SLIP Addresses . . . . .	3-3

Serial Port and PCMCIA Modem Default Settings	3-3
ASCII Terminal Setup Attributes	3-3
Configuration and Monitoring Tools	3-4
IBM 2216 Access Methods	3-6
Local and Remote Console Access	3-6
System Components Used for Access to the IBM 2216	3-6
IBM 2216 Hardware	3-6
Configuration Program	3-7
PCMCIA Modem	3-7
Managing the Operational and Configuration Software	3-7
IBM 2216 Software and Configuration Change Management	3-7
File Transfer	3-7
File Transfer Using TFTP or Xmodem	3-8
How Software Files Are Managed	3-9
How to View the Files	3-9
File Status Descriptions	3-10
How to Reset the IBM 2216	3-10
Using the Configuration Program to Manage the Configuration Files	3-11
Example of Sending a File from the Configuration Program	3-11
Using the Set Commands	3-12
Set Active Load Image	3-13
Set Active Configuration	3-13
Set Boot List	3-13
Set Serial Port	3-14
Other Change Management Functions	3-15
Describe Load Images	3-15
Describe Config Images	3-15
Disable Dumping	3-15
Enable Dumping	3-15
Erase Files	3-16
Using the Copy Command	3-16
<b>Chapter 4. Completing Worksheets</b>	4-1
Hardware Configuration Quick Reference	4-1
The Rack Inventory Chart	4-1
Initial Configuration Worksheet	4-1
Quick Configuration Worksheet	4-2
Token-Ring Configuration Worksheet	4-2
<b>Chapter 5. Quick Configuration</b>	5-1
Configuring the IBM 2216 Using Quick Configuration Sample	5-2
Configuring Bridging	5-2
Configuring Protocols	5-4
Configuring IP	5-5
Configuring IPX	5-7
Configuring DECnet (DNA)	5-9
Restarting the IBM 2216	5-11
Full Configuration	5-12
<b>Appendix A. Cable Specifications</b>	A-1
Service Port	A-1
Wide Area Networks (WANs)	A-1
Disclaimer	A-2
EIA 232-E/V.24 (FC 2705 and 2706)	A-3

V.35 (FC 2707 and 2708)	A-4
V.36 (FC 2709 and 2710)	A-6
X.21 (FC 2711 and 2712)	A-8
<b>Appendix B. Common Tasks</b>	<b>B-1</b>
LED States / Adapter Status	B-1
The Firmware Interface	B-1
Command Line Interface	B-1
Displaying List of Active Interfaces	B-1
Displaying the Operational State of the Interfaces	B-2
Verifying Connectivity	B-2
Viewing Vital Software Data	B-2
Viewing Vital Hardware Data	B-3
Adding an Adapter at Initial Configuration	B-3
Adding an Adapter after Initial Configuration	B-4
Running Quick Configuration	B-5
Disabling an Adapter Port	B-5
Enabling an Adapter Port	B-5
Disabling an Adapter Port to Suspend Traffic	B-6
Enabling an Adapter Port to Resume Traffic	B-6
Removing and Deleting an Adapter	B-7
Running Diagnostics	B-7
Up-to-Date IBM 2216 Information	B-7
Disabling Interfaces that have WAN Reroute Enabled	B-8
Enable WAN Reroute after you have Disabled it	B-8
<b>Appendix C. Charts and Worksheets</b>	<b>C-1</b>
Quick Configuration Worksheet	C-3
Initial Configuration Worksheet	C-6
Token-Ring Configuration Worksheet	C-7
LLC Configuration Worksheet	C-8
<b>Appendix D. Factory Plugging Defaults</b>	<b>D-1</b>
Assumptions	D-1
Plugging Sequences	D-1
<b>Appendix E. Management of Routing Networks</b>	<b>E-1</b>
Network Characteristics	E-1
Basic Principles	E-1
Configuration Control	E-1
The Network Engineer	E-1
Central Control Point (Network Management Center)	E-2
Step-by-Step Configurations	E-2
IP Connectivity	E-2
One Protocol at a Time	E-2
Patience	E-2
Configuration and Network Debugging	E-3
Many Types of Errors	E-3
Generate New Configurations	E-3
The Network Organization	E-3
Network Management Center	E-3
Network Monitoring	E-3
Network Coordination	E-4
Network Control	E-4

Network Engineer	E-5
Network Support Team	E-5
Network Manager	E-6
Configuration Management	E-6
Configurations	E-6
Configuration Sets	E-7
Naming Conventions	E-7
Concepts	E-7
Configuration Database Names	E-7
Configuration File Names	E-8
Router Configuration Changes	E-8
Changes to a Router	E-9
Hardware Changes that Affect the Network	E-9
Hardware Changes that Do Not Affect the Network	E-10
Router Code Updates	E-10
Network Changes	E-11
Configuration Build Sequence	E-11
Network Configuration Changes	E-11
Network Code Updates	E-12
Network Expansion Example	E-12
1. Preparation by the NMC	E-12
2. Key Installation Steps	E-13
3. Network Roll-Out Plan	E-14
Network Expansion Requirements	E-14
Network Configuration Changes	E-15
<b>Appendix F. Notices</b>	F-1
Electronic Emission Notices	F-1
European Community (EC) Mark of Conformity Statement	F-4
Japanese Voluntary Control Council for Interference (VCCI) Statement	F-4
Korean Communications Statement	F-5
Trademarks	F-5
<b>Glossary</b>	X-1
<b>Index</b>	X-9



---

## Tables

2-1.	Routing Subsystem Console Commands Supported Routing and Bridging Protocols . . . . .	2-2
2-2.	IBM 2216 Adapters and Feature Codes . . . . .	2-3
2-3.	Power Cords and Power Plug Standards . . . . .	2-11
3-1.	File Transfer . . . . .	3-8
A-1.	Service Port Signal Definitions . . . . .	A-1
A-2.	EIA 232/V.24 Connector Pin Assignments, 25-pin D, Male, Modem-Attach . . . . .	A-3
A-3.	EIA 232/V.24 Connector Pin Assignments, 25-pin, D, Female, Direct-Attach . . . . .	A-3
A-4.	V.35 Connector Pin Assignments, 34-pin Block, Male, Modem-Attach . . . . .	A-4
A-5.	V.35 Connector Pin Assignments, 34-pin Block, Female, Direct-Attach . . . . .	A-5
A-6.	V.36 Connector Pin Assignments, 37-pin D, Female to Female, Modem-Attach . . . . .	A-6
A-7.	V.36 Connector Pin Assignments, 37-pin D, Female to Male, Direct-Attach . . . . .	A-7
A-8.	X.21 Connector Pin Assignments, 15-pin D, Male . . . . .	A-8
A-9.	X.21 Connector Pin Assignments, 26-pin D, Male to 15-pin Female . . . . .	A-8
C-1.	Initial Configuration Worksheet . . . . .	C-6
C-2.	Token-Ring Configuration Worksheet . . . . .	C-7
C-3.	LLC Configuration Worksheet . . . . .	C-8
D-1.	Slot Numbering . . . . .	D-1
D-2.	FC 2280s (LIC 280s) and FC 2281s (LIC 281s) . . . . .	D-1
D-3.	All Other Adapters . . . . .	D-1



---

## Figures

2-1.	Power Cord Plugs by Country . . . . .	2-12
3-1.	Remote Serial Connection to the PCMCIA Modem . . . . .	3-2
3-2.	Local Serial Connection to the EIA 232 Port . . . . .	3-2



---

## About This Manual

---

### Who Should Read This Manual

This manual provides planning information and installation procedures for the IBM 2216 Nways Multiaccess Connector (hereafter referred to as the *IBM 2216*). It also provides information on the management of routing networks. The intended user is the person responsible for planning the setup and configuration of one or more IBM 2216s.

---

### How This Manual Is Organized

This manual contains the following chapters and appendixes:

Chapter 1, "Introduction" contains introductory information for the IBM 2216. It covers tasks to perform **before** installing your IBM 2216.

Chapter 2, "Planning and Technical Details" contains detailed technical information about the IBM 2216.

Chapter 3, "Accessing and Managing the IBM 2216" contains information on accessing the IBM 2216 in order to perform initial configuration and ongoing maintenance.

Chapter 4, "Completing Worksheets" is an overview of records that you should keep about your network.

Chapter 5, "Quick Configuration" provides instructions for performing a "quick configuration" of the IBM 2216. It covers tasks to perform **after** installing your IBM 2216.

Appendix A, "Cable Specifications" contains cable specifications for the service port and the WAN interfaces.

Appendix B, "Common Tasks" contains a series of questions and answers regarding the installation, configuration, and operation of the IBM 2216 to serve as a guide for performing various common tasks.

Appendix C, "Charts and Worksheets" provides worksheets for configuring your IBM 2216.

Appendix D, "Factory Plugging Defaults" describes the sequence in which adapters are installed at the factory.

Appendix E, "Management of Routing Networks" provides basic information and examples of routing network management techniques.

---

## How Do I Proceed?

Determine which adapters and cables to order and the network configuration. Document all of the network information that will be required to install, connect, and configure the IBM 2216.

Take the following steps to plan and install your IBM 2216:

- **1** Determine which adapters and cables you will need. Chapter 2, “Planning and Technical Details,” has details about available options. Design your network and place your order for your IBM 2216s and cables. (Cables are described in Appendix A, “Cable Specifications” on page A-1.)
- **2** Obtain and install the required common carrier equipment and services, including ATM, if necessary.
- **3** Obtain and install the required LAN equipment and services.
- **4** Order and install any required cables not included with the IBM 2216, such as ATM multimode and single-mode fiber cables that you will need to set up your network.
- **5** Obtain and install the hardware and software required to run the Configuration Program, as described in “Hardware and Software Requirements for the Configuration Program” on page 2-13.
- **6** Prepare Quick Configuration and Initial Configuration worksheets. These worksheets are in “Quick Configuration Worksheet” on page C-3. Help in preparing them is in Chapter 4, “Completing Worksheets.”
- **7** Prepare your site physically, ensuring that you meet the necessary power and environmental requirements. See “Preparing the Machine Area” on page 2-9.
- **8** Install the IBM 2216 using the *Hardware Installation Guide* provided with the product. (Alternatively, installation by IBM service personnel is available. Contact your IBM Representative for additional information.)
- **9** Connect a terminal to the serial port or PCMCIA modem to enable you to do configuration steps. (See “Accessing the IBM 2216” on page 3-1.)
- **10** Access the IBM 2216 firmware to do initial configuration. (See “The Firmware Interface” on page B-1.)
- **11** Create network interfaces for each port of each adapter that is installed in the 2216 using the **Add Device** command. (See “Adding an Adapter at Initial Configuration” on page B-3 for information in using the “Add Device” command.)
- **12** Run the “Quick Configuration” program to bring your IBM 2216 up on the network. See Chapter 5, “Quick Configuration.”
- **13** Perform final configuration. See *Configuration Program User’s Guide* and *Software User’s Guide*.

Planning and Installation

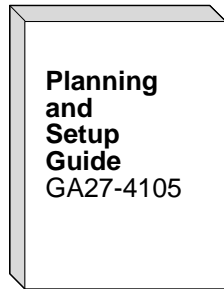

Configuration

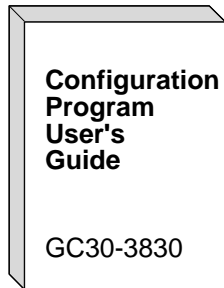

Diagnostics/Maintenance

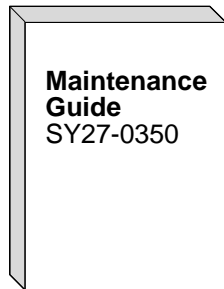

Operations and Network Administration

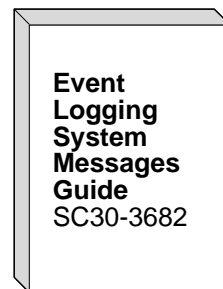
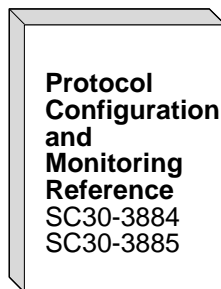
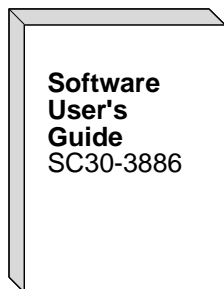

---

## Library Overview

The following list shows the books in the IBM 2216 library, arranged according to tasks.

**Information updates and corrections:** To keep you informed of engineering changes, clarifications, and fixes that were implemented after the books were printed, refer to the IBM 2216 home pages at:

<http://www.networking.ibm.com/216/216prod.html>  
and  
<http://www.networking.ibm.com/216/216lib.html>

### Planning

GA27-4105 *2216 Nways Multiaccess Connector Planning and Setup Guide*

This book is shipped with the IBM 2216. It explains how to prepare for installation and perform an initial configuration.

### Installation

GA27-4106 *2216 Nways Multiaccess Connector Hardware Installation Guide*

This booklet is shipped with the IBM 2216. It explains how to install the IBM 2216 and verify its installation.

GX27-3988 *2216 Nways Multiaccess Connector Hardware Configuration Quick Reference*

This reference card is used for entering and saving hardware configuration information used to determine the correct state of an IBM 2216.

### Diagnostics and Maintenance

SY27-0350 *2216 Nways Multiaccess Connector Maintenance Guide.*

This book is shipped with the IBM 2216. It provides instructions for diagnosing problems with and repairing the IBM 2216.

### Operations and Network Management

The following list shows the books that support the Nways Multiprotocol Access Services program.

SC30-3886 *Nways Multiprotocol Access Services Software User's Guide*

This book explains how to:

- Configure, monitor, and use the Nways Multiprotocol Access Services software.
- Use the Nways Multiprotocol Access Services command-line router user interface to configure and monitor the network interfaces and link-layer protocols shipped with the IBM 2216.

SC30-3884 *Nways Multiprotocol Access Services Protocol Configuration and Monitoring Reference, Volume 1*

SC30-3885 *Nways Multiprotocol Access Services Protocol Configuration and Monitoring Reference, Volume 2*

These books describe how to access and use the Nways Multipro-



to col Access Services command-line user interface to configure and monitor the routing protocol software shipped with the product.

They include information about each of the protocols that the devices support.

SC30-3682 *Nways Event Logging System Messages Guide*

This book contains a listing of the error codes that can occur, along with descriptions and recommended actions to correct the errors.

**Configuration**

GC30-3830 *Configuration Program User's Guide*

This book discusses how to use the Nways Multiprotocol Access Services Configuration Program.

**Safety**

SD21-0030 *Caution: Safety Information—Read This First*

This book, shipped with the IBM 2216, provides translations of caution and danger notices applicable to the installation and maintenance of a IBM 2216.

**Marketing**

URL: <http://www.networking.ibm.com/216/216prod.html>

This IBM Web page provides product information through the World Wide Web.



---

## Chapter 1. Introduction

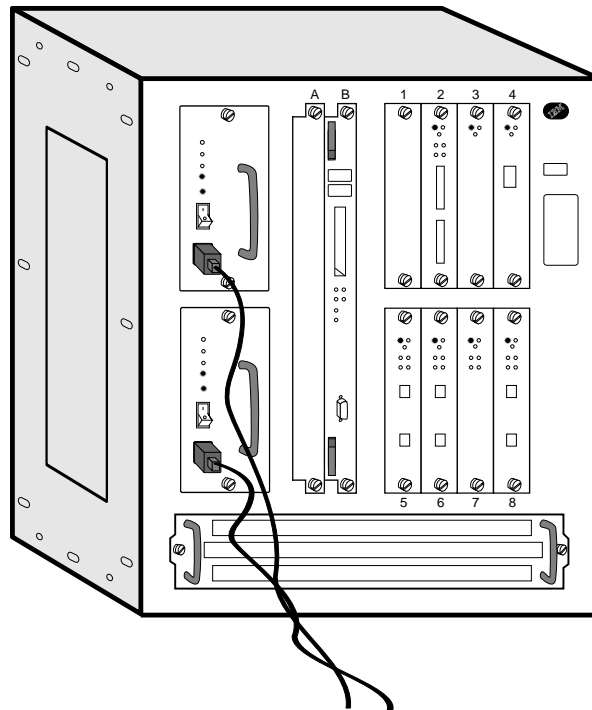

The IBM 2216 Nways Multiaccess Connector provides an answer to the problem of interconnecting networks using multiple protocols, devices, and lines. It gives the networking customer a method of routing and bridging across LANs and WANs, supporting a variety of network protocols across various types of media.

The IBM 2216 can play a vital role by interconnecting sites to support network computing. It enables you to:

- Improve the capabilities of your networks to provide information to field organizations, product development teams, customer service personnel, and your customers and suppliers
- Exploit intranets to improve access to internal information
- Use the Internet to transact business electronically with your customers and suppliers
- Maximize the potential of your networks
- Optimize your networks by consolidating branch office traffic, Frame Relay connections from multiple FRADs or APPN HPR traffic from remote SNA controllers
- Consolidate your SNA and IP networks with a single network that supports both efficiently

- Acquire a platform with growth capabilities that eases the transition to future network requirements

The 2216 provides wide area network access, network optimization, device attachment and concentration. It fits naturally between IBM's workgroup and campus routers and switches and its high-capacity broadband switches as an exciting new network computing building block.

### **IBM 2216 Highlights**

The IBM 2216 offers the following advantages over the equipment you may be currently using:

- Superior scalability
- Broad range of network connectivity choices
- Adaptability to a wide range of network configurations
- High system availability
- Maximum network availability
- Easy configuration, installation, and maintenance
- Superior serviceability

### **Additional Technical Details**

**Superior scalability:** The 2216 can support up to 64 attachments for device access or network consolidation. The 2216 has eight adapter slots with up to eight interfaces per adapter, giving it more than five times the WAN capacity of the largest 2210 Nways router. This makes it an excellent choice for data center access or regional concentration of remote branch offices.

**Broad range of network connectivity choices:** The 2216 uses the same routing, bridging, and SNA capabilities proven in the 2210 Nways router. These functions, called *Multiprotocol Access Services*, include standards-based, interoperable support for routing and bridging, with security and rerouting, on leased and switched networks.

Multiprotocol Access Services includes the following functions:

- Advanced SNA data transport, with APPN network node (NN), high performance routing (HPR), dependent LU requestor (DLUR), data link switching (DLSw, or RFC 1795, including NetBIOS support), and support for LAN Network Manager protocols
- All common routing protocols, including IP, IPX\*\* AppleTalk\*\* 2, Banyan VINES\*\*, DECnet\*\* IV and DECnet V/OSI  
IP routing includes ICMP, TCP, UDP, RIP, OSPF V2, BGP-4, static routes, Multicast Extensions to OSPF (MOSPF), ARP, InARP and IP Access Controls.
- All common bridging techniques, including transparent, source-route, source-route transparent, source-route to transparent translational bridging, and IP bridging tunnels
- The two primary forms of handling data traffic over ATM links, ATM Forum-compliant LAN Emulation (LANE), and Classical IP
- V.25 bis and ISDN PRI switched network access with worldwide ISDN software options, WAN restore, and dial-on-demand
- Frame relay (RFC 1490 including boundary access node [BAN] support), PPP, X.25 DTE, both primary and secondary SDLC

- WAN reroute is supported for recovery from Frame Relay, PPP or X.25 link failures
- Bandwidth reservation to assign traffic priority is supported over Frame Relay and PPP

**Adaptability to a wide range of network configurations:** You can choose from among the following attachments:

- 2-port Token-Ring
- 2-port Ethernet
- 8-port EIA-232E/V.24
- 6-port V.35 or V.36
- 8-port X.21
- 1-port ISDN PRI for E1 (30 B+D)
- 1-port ISDN PRI for T1/J1 (23 B+D)
- 1-port 155-Mbps ATM single-mode fiber
- 1-port 155-Mbps ATM multimode fiber

See “Options” on page 2-3 for more information about these adapters. Adapters can be positioned in any slot (with the exceptions as described in “Slots and Adapters” on page 2-8).

**High system availability:** The 2216 has a number of design features that maximize its availability and the availability of the networks to which it connects.

The hardware supports a high degree of redundancy and non-disruptive operation with:

- Optional dual power supplies that share the 2216 power load. Each has its own power cord for connection to independent power sources. If a power supply fails, the 2216 continues with the operational supply.
- Individually powered adapters that can be inserted or removed while the 2216 is operational. Failed adapters can be replaced without taking down the system or rebooting the software. Replaced adapters assume the configuration of the adapter they replace.
- System cooling with multiple fans that can maintain safe operating temperatures if a fan fails.
- Extensive environmental monitoring that tracks system operation and allows operators to correct potentially critical situations before they cause outages.

**Maximum network availability:** The 2216 software increases system and network availability with:

- Dial backup to bypass failed connections using either V.25 bis or an ISDN Primary Rate interface
- Routing around failed frame relay, PPP, or X.25 links

**Easy configuration, installation and maintenance:** The 2216 takes on average less than two hours to install. Initial configuration to connect the 2216 to a network is done using either a local ASCII terminal or an ASCII terminal connected via a modem. Subsequent configuration can be done using a graphical configuration program running on AIX, OS/2, or Windows\*\*.

Once configured, the 2216 can be managed by an SNMP manager. IBM provides comprehensive, easy-to-use graphical administration, management, problem anal-

ysis, and reporting software as a component of its Nways Managers which are available for AIX and HP OpenView.

**Superior serviceability:** Adapters, power supplies, cooling subassembly, and the processor card are accessible from the front panel, allowing replacement in seconds without having to remove the 2216 from a rack or remove its covers. The 2216 maintains its configuration and operating history in nonvolatile storage, speeding problem identification and diagnostics. An integrated modem is available in most countries for remote diagnostics. These features are combined with globally available, on-site support and field replacement of failed components 24 hours a day, 7 days a week.

## Benefits

The IBM 2216:

- Provides a broad range of LAN, WAN, and ATM network connection options, allowing flexible, money-saving network consolidation at regional concentration points or data centers
- Offers the functions of a multiprotocol router, FRAD and SNA remote controller, in a single product with high port density and the ability to connect and concentrate diverse networks, reducing acquisition and operating costs
- Delivers guaranteed compatibility with IBM 2210 and the IBM campus MSS solutions
- Provides a cost-effective, scalable solution, with eight adapter slots that can expand to accommodate new technologies as needed, when needed
- Uses Multiaccess Services software, with rich routing and bridging functions proven in the 2210 Nways router, maximizing interoperability and commonality and minimizing the need for operator training
- Provides an excellent solution for SNA remote concentration, with multiple SNA options including Frame Relay BAN, DLSw, and APPN HPR
- Offers flexible dial backup to recover from failures and dial-on-demand to minimize network line costs
- Minimizes the possibility of failure and the time to recover from failure with highly redundant hardware, fast reboot for rapid reconfiguration, and excellent serviceability
- Minimizes total cost of operation with easy-to-use tools for rapid installation and configuration and integrated, remote, graphical management tools

## Hardware Ordering Information

Prices and part numbers for all IBM 2216 components can be obtained from our 2216 web site (<http://www.networking.ibm.com/216/216fact.html>).

---

## Chapter 2. Planning and Technical Details

The software that supports the IBM 2216 is Nways Multiprotocol Access Services, a licensed program (program number 5765-B87), with the following components:

- The code that provides the routing, bridging, data link switching, and SNMP agent functions for the IBM 2216. This code also includes a monitoring system, which allows you to perform change management, network management, problem determination, and configuration. The base code is installed at the factory on the IBM 2216.
- The Configuration Program, which offers a graphical user interface that allows you to configure the IBM 2216 from a stand-alone workstation. See “Hardware and Software Requirements for the Configuration Program” on page 2-13.

---

### Networks Supported by the IBM 2216

The LANs supported by the IBM 2216 are:

- Token-ring (IEEE 802.5) with STP or UTP connection
- Ethernet or IEEE 802.3 with 10BASE2 or 10BASE-T connection

The interfaces supported by the IBM 2216 are:

- EIA-232E/V.24
- V.35
- V.36
- X.21
- ISDN—Primary (T1)
- ISDN—Primary (E1)
- ATM 155-Mbps multimode fiber
- ATM 155-Mbps single-mode fiber

## Protocols Supported by the IBM 2216

Table 2-1 shows the protocols supported by each IBM 2216 interface.

Table 2-1. Routing Subsystem Console Commands Supported Routing and Bridging Protocols

Framing Methods	WANs					LANs			
	PPP	FR	X.25	SDLC	Serial and ISDN		Token-Ring	Ethernet	ATM
					Dial on Demand	Dial Backup			
<b>Protocols</b>									
Banyan VINES	yes	yes	yes	no	yes	yes	yes	yes	yes
TCP/IP	yes	yes	yes	no	yes	yes	yes	yes	yes
DECnet IV	yes	yes	yes	no	yes	yes	yes	yes	yes
DECnet V/OSI	yes	yes	yes	no	yes	yes	yes	yes	yes
BGP	yes	yes	yes	no	yes	yes	yes	yes	yes
NetBIOS	yes	yes	yes	no	yes	yes	yes	yes	yes
LNLM	yes	yes	yes	no	yes	yes	yes	no	yes
IPX	yes	yes	yes	no	yes	yes	yes	yes	yes <sup>2</sup>
AppleTalk	yes	yes	yes <sup>1</sup>	no	yes	yes	yes	yes	yes
SNA	yes	yes	yes	yes	yes	yes	yes	yes	yes
SRB	yes	yes	yes	no	yes	yes	yes	no	yes
TB	yes	yes	yes	no	yes	yes	no	yes	yes
SRT	yes	yes	yes	no	yes	yes	yes	yes	yes
SR/TB	yes	yes	yes	no	yes	yes	yes	yes	yes

**Notes:**

1. X.25 routing is accomplished using IP Bridging Tunnel over X.25.
2. IPX is supported using Token-Ring and Ethernet LAN emulation. In addition, IPX is supported between routers that support RFC 1483 encapsulation.

## Features Supported

The base IBM 2216 consists of:

- A 19-inch cabinet, which can either be placed on a tabletop or installed in a rack
- One power supply (with redundant power option)
- A cooling fan tray assembly
- A system backplane
- A system card containing:
  - A 604 133-Mhz PowerPC microprocessor
  - 64-MB DRAM
  - A 512-KB L2 cache
  - A 1.08-GB IDE hard drive
- Eight adapter slots
- A PCMCIA modem (where available):
  - A 28.8-Kbps data modem with integrated DAA for the U.S. and Canada
  - A 28.8-Kbps data modem with programmable DAA for countries other than the U.S. and Canada



## Options

**Note:** Adapters can be inserted and removed while the IBM 2216 is operational. Failed adapters can be replaced without taking the system down or rebooting the software. The replaced adapter assumes the configuration of the failed adapter. New adapters can be added without powering the system down and activated at a convenient time by rebooting.

The following adapters are available for the IBM 2216. Each adapter is followed by its feature code.

Table 2-2. IBM 2216 Adapters and Feature Codes

Adapter	Feature Code (FC)
2-port Token-Ring	2280
2-port Ethernet	2281
8-port EIA-232E/V.24	2282
1-port ISDN-PRI (T1/J1 interface)	2283
1-port ATM 155-Mbps MMF	2284
6-port V.35/V.36	2290
8-port X.21	2291
1-port ISDN-PRI (E1 interface)	2292
1-port ATM 155-Mbps SMF	2293

### 2-port Token-Ring (FC 2280)

Provides for two attachments to Token-Ring LANs. This adapter can continually process frames of data to and from system memory and the Token Ring at a speed of either 4 Mbps or 16 Mbps. It supports the use of either shielded twisted-pair and unshielded twisted-pair cable through a single connector. Cable 2713 is available for this adapter.

### 2-port Ethernet (FC 2281)

Provides for two attachments to Ethernet LANs. It supports the use of either 10BASE-T cable or 10BASE2 cable. Cable 2713 is available for this adapter.

### 8-port EIA-232E/V.24 Adapter (FC 2282)

Provides eight attachments to EIA-232E/V.24 WANs. Each attachment provides:

- Support for receiving clocking (modem-attached) at a line speed from 2.4 Kbps to 64 Kbps
- Support for providing clock (directly attached) from 9.6 Kbps to 64 Kbps
- Software selectable to receive clock (modem-attached) or provide clock (directly attached) with the appropriate cable
- A 100-pin D-shell female connector
- Support for cables FC 2701, FC 2705, and FC 2706

### 1-port ISDN PRI (T1/J1) Adapter (FC 2283)

Provides one attachment to an ISDN Primary Rate service at T1/J1 speed. This attachment provides:

- Support for T1/J1 line speed of 1.544 Mbps
- Twenty-three 64 Kbps B-channels for data and one 64-Kbps D-channel for signaling.
- Selectable framing to D4 (SF), D5 (ESF), or SLC-96R formats
- Detection and generation of yellow and blue alarms
- Facility Data Link (FDL) support

- Generation of DSX-1 and CSU line build outs
- Generation and detection of CSU loop codes
- Line error counters for BPV, CV, CRC6, and framing-bit errors
- Monitoring and enforcing of ANSI ones density requirement
- Extraction and insertion of robbed bit signaling
- B8ZI and AMI line coding
- DB-26 (26-pin D-shell) female connector
- Support for cables FC 2714 and FC 2716

### **1-port ATM 155-Mbps Multimode Fiber Adapter (FC 2284)**

Provides one attachment to an ATM switch over a multimode fiber optic cable. Each attachment provides:

- 8 MB of packet memory and 2 MB of control memory for high-performance support
- A specialized ATM support chip to perform the segmentation and reassembly (SAR) function for ATM Adaptation Layer 5 (AAL-5)
- SONET OC3c framing
- Nominal operating wavelength of 1300 nm using LED-based technology
- Support for a 62.5/125 $\mu$ m multimode fiber
- A multimode duplex SC connector

**Note:** A cable is not provided with the IBM 2216 for this adapter.

### **6-Port V.35/V.36 Adapter (FC 2290)**

Provides six attachments to ITU-T V.35 or V.36 WANs. Each attachment provides:

- Support for receiving clocking (modem-attached) at a line speed from 2.4 Kbps to 2.048 Mbps
- Support for providing clock (directly attached) from 9.6 Kbps to 460.8 Kbps as well as 1.544 Mbps and 2.048 Mbps
- Software selectable to receive clock (modem-attached) or provide clock (directly attached) with the appropriate cable
- A 100-pin D-shell female connector
- Support for cables FC 2702, FC 2703, FC 2707, FC 2708, FC 2709 FC 2710, and FC 2799

With the V.35/V.36 you can use the following combination of cables:

- FC 2702 with FC 2707, FC 2708, and FC 2799 (for V.35)
- FC 2703 with FC 2709 and FC 2710 (for V.36)

**Note:** Cabling to mix V.35 and V.36 interfaces on adapter FC 2290 is not provided.

### **8-Port X.21 Adapter (FC 2291)**

Provides eight attachments to ITU-T X.21 WANs. Each attachment provides:

- Support for receiving clocking (modem-attached) at a line speed from 2.4 Kbps to 2.048 Mbps
- Support for providing clock (directly attached) from 9.6 Kbps to 460.8 Kbps as well as 1.544 Mbps and 2.048 Mbps

- Software selectable to receive clock (modem-attached) or provide clock (directly attached) with the appropriate cable
- A 100-pin D-shell female connector
- Support for cables FC 2704, FC 2711, and FC 2712

### **1-port ISDN PRI (E1) Adapter (FC 2292)**

Provides one attachment to an ISDN Primary Rate service at E1 speed. This attachment provides:

- Support for E1 line speed of 2.048 Mbps
- Thirty 64-Kbps B-channels for data and one 64-Kbps D-channel for signaling
- Selectable framing to FAS, CAS, and CRC4 formats
- Detection and generation of remote and AIS alarms
- Full access to both Si and Sa bits
- Generation of line build outs for a 120-ohm line
- Three separate loopbacks for testing
- Line error counters for bipolar and code violations, CRC4 code word errors, FAS errors, and E-bits
- Extraction and insertion of CAS signaling
- B8ZI and AMI line coding
- DB-26 (26-pin D-shell) female connector
- Support for cable FC 2715.

### **1-port ATM 155-Mbps Single-Mode Fiber Adapter (FC 2293)**

Provides one attachment to an ATM switch over a single-mode fiber optic cable. Each attachment provides:

- 8 MB of packet memory and 2 MB of control memory for high-performance support
- A specialized ATM support chip to perform the segmentation and reassembly (SAR) function for ATM Adaptation Layer 5 (AAL-5)
- SONET OC3c framing
- Nominal operating wavelength of 1310 nm using laser-based technology
- Support for a 9/125 $\mu$ m single-mode fiber
- Transceiver support for a maximum cable length of 20 km (12.4 miles)
- A single-mode polarized duplex SC connector

**Note:** A cable is not provided with the IBM 2216 for this adapter.

## **Cables**

The following adapter cables are available for use with the IBM 2216.

- EIA-232E/V.24 Fanout Cable (FC 2701)

This fanout cable provides eight connections (25-pin D-shell male) each of which is 1.8 meters (5.2 feet) in length. Each connection is suitable for connection to a EIA-232/V.24 modem.

Cables 2705 and 2706 are available to complement this cable. FC 2705 attaches to the FC 2701 and extends the cable length an additional 3 meters (10 feet) for attachment to a modem. FC 2706 attaches to FC 2701 and provides clocking to allow devices to be directly attached to the IBM 2216 without

having to use a modem. It is 3 meters (10 feet) in length and provides a female 25-pin D-shell connector.

- V.35 Fanout Cable (FC 2702)

This fanout cable provides a 1.2-meter (4-foot) cable to a distribution box containing six 25-pin D-shell male connectors.

Cables 2707 and 2708 are available to complement this cable. FC 2707 provides a 3-meter (10-foot) extension cable with a 34-pin male block connector for attachment to a modem. FC 2708 provides a 2-meter (6.6-foot) cable with a 34-pin female block connector for direct-device attachment.

- V.36 Fanout Cable (FC 2703)

This fanout cable provides six connections (37-pin D-shell male) each of which is 3 meters (9.8 feet) in length. Each connection is suitable for connection to a V.36 modem.

Cables 2709 and 2710 are available to complement this cable. FC 2709 provides a 3-meter (10-foot) extension cable with a 37-pin male D-shell connector for attachment to a modem. FC 2710 provides a 3-meter (10-foot) cable with a 37-pin female D-shell connector for direct-device attachment.

- X.21 Fanout Cable (FC 2704)

This fanout cable provides eight connections (15-pin D-shell male) each of which is 1.8 meter (5.9 feet) in length. Each connection is suitable for connection to an X.21 modem.

Cables 2711 and 2712 are available to complement this cable. FC 2711 provides a 3-meter (10-foot) extension cable with a 15-pin D-shell male connector for attachment to a modem. FC 2712 provides a 3-meter (10-foot) cable with a 15-pin D-shell female connector for direct-device attachment.

- EIA-232E/V.24 Serial Interface Cable (FC 2705)

This cable provides a 3-meter (10-foot) extension cable with a 25-pin D-shell male connector for attachment to a modem.

- EIA-232E/V.24 Direct Attach Cable (FC 2706)

This cable provides a 3-meter (10-foot) cable with a 25-pin D-shell female connector for direct-device attachment.

- V.35 Serial Interface Cable (FC 2707)

This cable provides a 3-meter (10-foot) extension cable with a 34-pin male block connector for attachment to a modem.

- V.35 Direct Attach Cable (FC 2708)

This cable provides a 2-meter (6.6-foot) cable with a 34-pin female block connector for direct-device attachment.

- V.36 Serial Interface Cable (FC 2709)

This cable provides a 3-meter (10-foot) extension cable with a 37-pin male D-shell connector for attachment to a modem.

- V.36 Direct Attach Cable (FC 2710)

This cable provides a 3-meter (10-foot) cable with a 37-pin female D-shell connector for direct-device attachment.

- X.21 Serial Interface Cable (FC 2711)

This cable provides a 3-meter (10-foot) extension cable with a 15-pin D-shell male connector for attachment to a modem.

- X.21 Direct Attach Cable (FC 2712)

This cable provides a 3-meter (10-foot) cable with a 15-pin D-shell female connector for direct-device attachment.

- Multipurpose RJ-45 Adapter Cable (FC 2713)

This cable provides a 7.6-meter (25-foot) Category 5 cable with an RJ-45 connector for attachment to token-ring hubs or switches or Ethernet 10BASE-T hubs or switches.

- RJ-48 T1 ISDN PRI Cable (FC 2714)

This cable provides a 15-meter cable with an RJ-48 connector for attachment to T1 ISDN PRI switches.

- ISDN PRI (E1) Cable (FC 2715)

This cable provides a 30-meter (100-foot) cable with “flying leads” suitable for wiring to E1 ISDN PRI switches.

- RJ-48 J1 ISDN PRI Cable (FC 2716)

This cable provides a 15-meter (50-foot) cable with a RJ-48 connector for attachment to J1 ISDN PRI switches.

The following cable is available in France:

- Attachment Cable for V.35 DCE (FC 2799) - 30-cm

This cable provides a 30-cm (1-foot) cable that adapts the standard V.35 34-pin male block connector to the connector required for attachment to V.35 modems in France.

The following cables are not provided as options for the IBM 2216 and must be obtained by the customer, as required:

- Token-Ring STP Network Adapter Cable
- Ethernet 10BASE2 Cable
- ATM multimode fiber adapter cable
- ATM single-mode fiber adapter cable

See Appendix A, “Cable Specifications” on page A-1.

---

## Slots and Adapters

There are two large slots, designated *A* and *B*, on the IBM 2216. Currently, slot *A* is unused. Slot *B* is occupied by the system card. In addition, there are eight adapter slots, designated 1 through 8.

Any adapter can be installed in any of the eight slots with the following restrictions:

- 1** The IBM 2216 supports a maximum of two ATM adapters (FC 2284 or FC 2293)
- 2** The IBM 2216 supports a maximum of four ISDN adapters (FC 2283 or FC 2292)
- 3** If the 2-port Token-Ring (FC 2280) or 2-port Ethernet (FC 2281) adapter is plugged into slot 3 and active, then slot 4 cannot be used.
- 4** If the 2-port Token-Ring (FC 2280) or 2-port Ethernet (FC 2281) is plugged into slot 4 and active, then slot 3 cannot be used.
- 5** If the 2-port Token-Ring (FC 2280) or 2-port Ethernet (FC 2281) adapter is plugged into slot 7 and active, then slot 8 cannot be used.
- 6** If the 2-port Token-Ring (FC 2280) or 2-port Ethernet (FC 2281) adapter is plugged into slot 8 and active, then slot 7 cannot be used.

## Factory Plugging Defaults

Units assembled at the factory follow certain plugging rules. These rules are described in Appendix D, "Factory Plugging Defaults" on page D-1.

---

## Placement Options

The IBM 2216 can be placed on a tabletop or in a rack.

### Tabletop

If the IBM 2216 is placed on a tabletop, the table must meet the requirements for service and operating clearances listed under "Service Clearances" on page 2-9.

### Rack

If you choose rack-mounting, you must provide the rack; it is not provided with the IBM 2216.

You can use any EIA standard 19-inch rack. The rack can be open or closed. However, if you choose a closed rack, you must make sure that enough air flows through the IBM 2216. Covers on the front of the rack that would not let air reach the IBM 2216 must be removed or modified to let air pass. Similarly, unvented rear rack covers that would not let air exit the IBM 2216 or that would cause back pressure to build up from several machines must not be used.

---

## Preparing the Machine Area

To prepare the area where the machine will be installed, you need to consider the following requirements:

- The physical dimensions of the machine
- The area that must be left free around the machine for easy access to the cables, connectors, and parts to be replaced.
- Environmental constraints

## Access to the Unit

All cables are attached at the front of the unit. In addition, all LEDs are on the front and all features are installed from the front. This simplifies setup and maintenance of the unit and minimizes the amount of service area required to access it.

---

## Physical Specifications

The dimensions of the IBM 2216 are as follows:

### Width

440 mm (17.3 inches) without rack mounting flange

480 mm (18.9 inches) with rack mounting flange

### Depth

358 millimeters (14.1 inches)

### Height

572 mm (22.5 inches) (13U) without rubber feet pads

576.1 mm (22.7 inches) (13U) with rubber feet pads

## Weight

The base box of the IBM 2216—with one power supply, system card, no adapters, a power supply filler plate, and no adapter filler plates—weighs 31.6 kg (69.7 lb). Each adapter weighs approximately 1 kg (2.2 lb). Each filler plate for an unoccupied adapter slot weighs 0.1 kg (0.2 lb). A filler plate for a second power supply weighs 0.2 kg (0.4 lb), while a second power supply weighs 3.5 kg (7.7 lb). A fully populated IBM 2216 with a second power supply and eight adapters will weigh about 43.1 kg (95 lb).

## Service Clearances

You must leave free space for service around the machine as follows:

**Front** 750 millimeters (30 inches)

**Sides** No clearance required

**Rear** No clearance required

## Airflow

A multiple-fan (forced air) ventilation system is installed in each unit. The airflow is 2.0 cubic meters per minute (71 cubic feet per minute).

## Environment

Operating Environment	
Temperature	10°C to 40.6°C (50°F to 105°F)
Relative Humidity	8% to 80%
Max Wet Bulb	27°C (80°F)

## Lightning Protection

The power supplies of the IBM 2216 are protected against lightning.

Contact an electrical contractor to determine if lightning protection is needed for your power distribution system.

## Electromagnetic Interference

The IBM 2216 is compatible with the following classes of interference:

- Comité International Spécial des Perturbations Radioélectriques (CISPR) Publication 22, Class A
- Federal Communication Commission (FCC), Part 15, Subpart J, class A (USA)
- General Operating Permit (GOP) (Germany)
- Voluntary Control Council for Interference (VCCI) Class 1 and IEC 1000-3-2 (Japan)

---

## Power Supply

The IBM 2216 can have one or two power supplies. A single power supply can provide power for a fully configured unit. The first power supply will remain fully operational while a second is either being installed or removed. The second power supply must have its power switch in the off position while it is being installed or removed. If a second power supply is not installed, a filler plate is used to cover the cavity where it would have been installed.

The power supply uses a voltage sensing system that converts line current of 100—240 volts ac, 50/60 Hz single-phase, to dc input as required by the system card, the adapters, and the fan tray.

## Power Supply Requirements

For the IBM 2216, the ac power source must be able to supply:

- 100 to 240 V ac (nominal voltage)
- 50 or 60 Hz
- Single phase
- 0.62 kVA power
- 70 amps peak inrush current for one quarter cycle per supply

## Power Cord Characteristics

The ac power cord is supplied with a country-dependent plug. For each of the cords listed in Table 2-3, find its plug type in Figure 2-1 on page 2-12 by comparing *index* numbers. (The index number is displayed below each plug type in Figure 2-1.)



Table 2-3. Power Cords and Power Plug Standards

Index	Part Number	Feature Code	Countries	Power Cord	Plug Standard
1	1838574	9833	Canada, Japan, Philippines, Taiwan, Thailand, Bolivia, Brazil, Ecuador, Peru, Venezuela, United States	250 V, 10 A, 2.7 m (9 ft)	NEMA WD-1 6-15P
2	6952300	9810	United States (except Chicago), Puerto Rico, Canada, Japan, South Korea, Philippines, Taiwan, Saudi Arabia, Mexico, Bolivia, Brazil, Colombia, Ecuador, Peru, Venezuela, Panama	125 V, 10 A, 2.7 m (9 ft)	NEMA WD-1 5-15P
2	6952301	9815	United States (Chicago only)	125 V, 10 A, 1.8 m (6 ft)	NEMA WD-1 5-15P
2	1838576	9818	United States (Chicago only)	250 V, 10 A, 1.8 m (6 ft)	NEMA WD-1 5-15P
3	13F9979	9820	Indonesia, South Korea, Macau, Austria, Belgium, Finland, France, Germany, Greece, Norway, Portugal, Saudi Arabia, Spain, Sweden, Turkey, Netherlands, China, Brazil	250 V, 10 A, 2.7 m (9 ft)	CEE7 VII
4	14F0033	9825	Brunei, China, Hong Kong, India, Malaysia, Singapore, Ireland, Kuwait, United Arab Emirates, United Kingdom	250 V, 10 A, 2.7 m (9 ft)	BS 1363
5	14F0051	9828	Switzerland, Liechtenstein	250 V, 10 A, 2.7 m (9 ft)	SEV 24507
6	14F0069	9830	Italy, Chile	250 V, 10 A, 2.7 m (9 ft)	CEI 23-16
7	13F9997	9821	Denmark	250 V, 10 A, 2.7 m (9 ft)	Normblad 4
8	14F0087	9827	Israel	250 V, 10 A, 2.7 m (9 ft)	SII-32-1971
9	13F9940	9831	Australia, New Zealand, Argentina, China	250 V, 10 A, 2.7 m (9 ft)	AS 3122-1981 NZS 198
9	6952291	9834	Argentina, Colombia, Brazil, Paraguay, Uruguay	250 V, 10 A, 2.7 m (9 ft)	IEC 83-A5 1957
10	14F0015	9829	Bangladesh, Myanmar, Sri Lanka, Pakistan, South Africa	250 V, 10 A, 2.7 m (9 ft)	SABS 164 BS 546

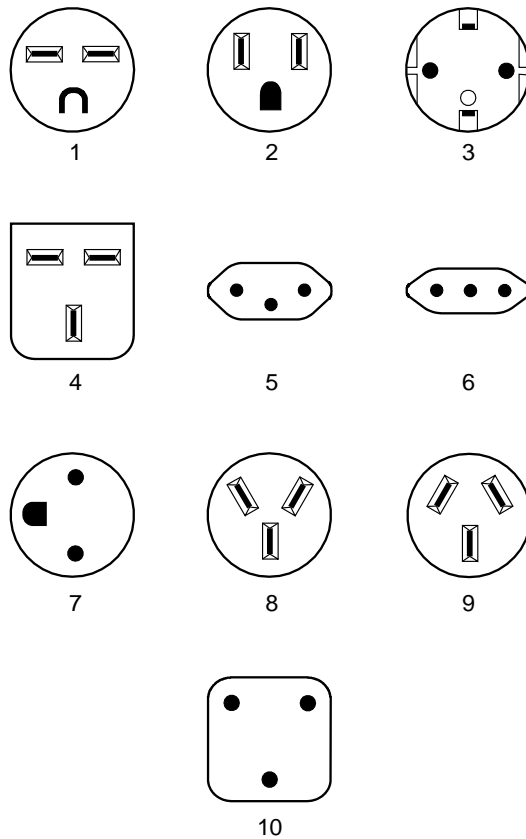

Figure 2-1. Power Cord Plugs by Country

## Hardware Requirements

You must provide the following hardware to operate the IBM 2216:

- Any cables that are not provided with the IBM 2216. See Appendix A, “Cable Specifications” for a list of IBM cable feature numbers.
- A modem is required for the IBM 2216. In most cases, this is a PCMCIA modem that is provided with the initial IBM 2216 order. For some countries, the modem is not available. Your IBM representative can tell you whether you will receive the modem. If the modem is not shipped with your IBM 2216, you will have to supply a modem that connects to the serial port. It must support the AT command set and one of the following protocols:
  - ITU-T V.32 at 9.6 Kbps
  - ITU-T V.32 bis at 14.4 Kbps
  - ITU-T V.34 at 28.8 Kbps

Whether you use the IBM modem or provide your own modem, you must set up a communications (telephone) line to the modem to use it. A workstation is required to access the IBM 2216. See Chapter 3, “Accessing and Managing the IBM 2216” for more information.

The required operational software is shipped preloaded on each IBM 2216.

---

## Hardware and Software Requirements for the Configuration Program

You can use the Configuration Program to prepare configuration files and then upload them to the IBM 2216. This method of configuration enables you to use the change management functions of the IBM 2216 that are described in “Managing the Operational and Configuration Software” on page 3-7.

**Note:** Using the Configuration Program is recommended for the final configuration of the IBM 2216 (after running the “Quick Configuration” program during the installation of the IBM 2216). The Configuration Program enables you to save and track configuration files. You can also make an ASCII copy of the completed configuration file to check its parameters before you download it to the IBM 2216.

The Configuration Program will operate on any of the following hardware and software operating environments:

- An IBM Personal System/2 (PS/2) computer or compatible computer that is running Microsoft Windows and has the following attributes:
  - Intel\*\* 80386\*\* or higher processor
  - IBM DOS 5.0 or MS\*\* DOS 5.0 or higher
  - MS Windows\*\* 3.1 or higher versions
    - Win32s\*\*, included with the Multiprotocol Access Services Configuration Program (not required for Windows 95\*\*)
    - WinSock 2.0 DLL (included with Win32s)
  - TCP/IP application that uses WinSock 2.0
  - 15 MB of memory
  - 1.44 MB, 3.5-inch diskette drive
  - 14 MB of free hard disk space
  - A graphics display that supports 640\*480 resolution and 16 colors or gray scale
  - A mouse

If you encounter problems because Windows does not update correctly, make sure that you have the latest BIOS and video drivers provided by the manufacturer.

- An RS/6000 POWERstation or POWERserver with the following attributes:
  - AIX for RS/6000 Version 3.2.5 or higher with TCP/IP enabled; (5756-030)
  - AIXWindows Environment/6000 (5601-257)
  - 16 MB of memory
  - 1.44 MB, 3.5-inch diskette drive
  - 14 MB of free hard disk space
  - A graphics display that supports 640\*480 resolution and 16 colors or grayscale
  - A mouse

If you plan to install a communication link between the Configuration Program on a RS/6000 workstation and the IBM 2216, the TCP/IP function in AIX/6000 3.2.5 (or higher) must be installed.

- An IBM PS/2 or compatible computer with the following attributes:
  - Intel\*\* 80386 or higher processor
  - IBM Operating System (OS/2) 2.1 or higher, including WARP
  - IBM TCP/IP 1.2.1 for OS/2 or higher
  - 15 MB of memory (16 MB recommended)
  - 1.44 MB, 3.5-inch diskette drive
  - 14 MB of free hard disk space
  - 10 MB of available swapper disk space on the swapper hard disk drive partition
  - A graphics display that supports 640\*480 resolution and 16 colors or grayscale
  - A mouse

If you encounter problems because Windows is not updating correctly, make sure that you have the latest BIOS and video drivers provided by the manufacturer.

---

## Chapter 3. Accessing and Managing the IBM 2216

This chapter explains how to access and manage the IBM 2216's operational and configuration software.

The network administrator or the IBM Support Center can access the IBM 2216 locally or remotely for configuration or diagnostics. The following sections describe accessing the IBM 2216, configuration tools, and monitoring tools.

---

### Accessing the IBM 2216

The IBM 2216 must be configured as part of the installation process. It needs either an IP address or configuration for LAN emulation. Therefore, you have to access it in one of the following ways:

- Through the PCMCIA modem or through a modem attached to the EIA 232 service port. These are the forms of remote connection, which rely on the telephone lines.
- Through a null modem cable attached to the EIA 232 service port. This is known as local connection.

You can set up both a local and a remote connection to the IBM 2216. However, only one port can be active at any given time. If a workstation is connected locally to the serial port and a call comes in over the PCMCIA modem, priority is given to the call. After the call, the workstation being used to configure will have to log back into the IBM 2216.

With local or remote connection, you can use a teletypewriter (TTY) connection. TTY requires communications software. The preferred method is to use Serial Line Internet Protocol (SLIP) over the local or remote connection. If you use SLIP, you must have Transmission Control Protocol/Internet Protocol (TCP/IP) running on your workstation.

Alternatively, you can use the Xmodem protocol and ProComm\*\* or other communication software for file transfers.

Figures 3-1 and 3-2 show remote connection using the PCMCIA modem, and a local connection,

**Note:** Post-installation configuration changes can be done using the Configuration Program. See "Configuration and Monitoring Tools" on page 3-4.

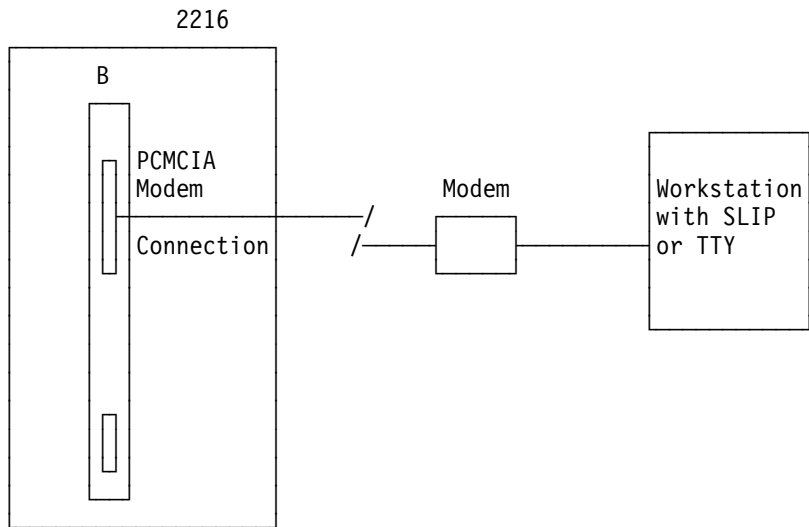

Figure 3-1. Remote Serial Connection to the PCMCIA Modem

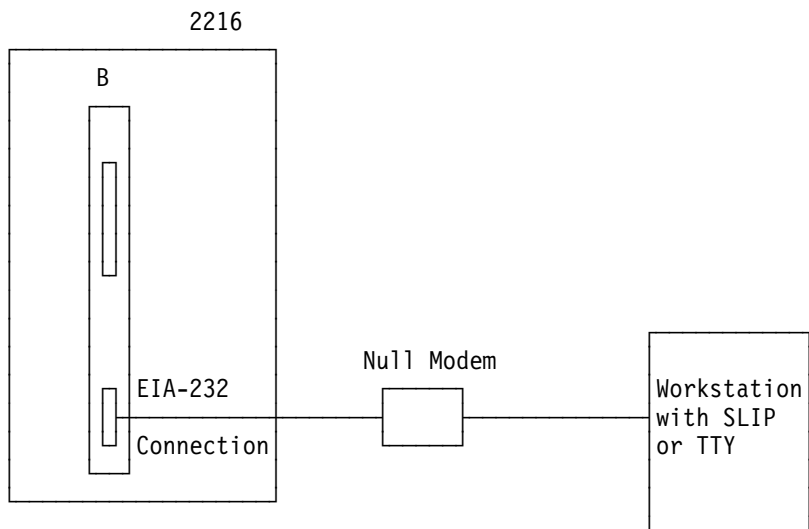

Figure 3-2. Local Serial Connection to the EIA 232 Port

## SLIP Addresses

The default SLIP IP addresses are:

**For the workstation:**

10.1.1.3

**For the IBM 2216**

10.1.1.2

For instructions about installing SLIP, refer to the documentation for your version of TCP/IP.

## Serial Port and PCMCIA Modem Default Settings

These are the default settings for the serial port:

<b>Speed</b>	19.2 Kbps
<b>Parity</b>	None
<b>Data Bits</b>	8
<b>Stop Bits</b>	1

The PCMCIA modem is a standard item that is shipped with the IBM 2216. The modem is a 28.8 Kbps V.32 bis modem. It is set up with a default speed of auto detect. The parity, data bits, and stop bits are the same as those of the serial port: None, 8, and 1.

---

## ASCII Terminal Setup Attributes

This is a list of all the options required to set up a terminal for use with the IBM 2216. Not every terminal (particularly 3151 and 3161) will have all these options. You should use the information to set the options that you can set on your terminal.

## Terminal Setup Attributes and Function Keys

### Terminal Settings:

Baud Rate: 19200 bits per second  
Parity: None  
Stop bits: 1

Duplex: Full Duplex  
Flow Control: XON/XOFF and RTS/CTS \*\*

Screen Control: ANSI Full screen  
Screen Width: 80 Characters  
Screen Height: 24 Lines  
Line Wrap: ON  
Screen Scroll: ON

Carriage Return Translation: CR (0Dx)  
Backspace Translation: Destructive

### Function Keys:

Function 1 (F1): <Esc> O P           Hex: 1B 4F 50  
Function 2 (F2): <Esc> O Q           Hex: 1B 4F 51  
Function 3 (F3): <Esc> O R           Hex: 1B 4F 52  
Function 4 (F4): <Esc> O S           Hex: 1B 4F 53

Function 6 (F6): <Esc> [ 0 0 6 q   Hex: 1B 5B 30 30 36 71  
Function 9 (F9): <Esc> [ 0 0 9 q   Hex: 1B 5B 30 30 39 71

### Note:

\*\* *Terminals and Terminal emulator programs which do not have flow control options should be set to "Permanent Request to Send".*

*Terminal emulators that require a terminal type selection should be set to VT-220.*

- *In the definitions of function keys 1 through 4, the character following the <ESC> is the capital letter O.*
- *In the definition of keys 6 and 9 the characters following the <ESC> and the [ are number 0 (zero).*

*In all six definitions, the characters are case sensitive.*

---

## Configuration and Monitoring Tools

These are the various configuration and monitoring tools that are supported by the physical connections:

### Multiprotocol Access Services Configuration Program

This is a standalone program that is installed in a workstation that is connected to the IBM 2216. The workstation must be running TCP/IP. You can transfer files to and from the configuration program using Xmodem Send,



TFTP over IP or SLIP, or the Communications Options feature of the configuration program.

The Communications Options feature requires that the configuration program run over AIX and that the IBM 2216 be configured with an IP address, a subnet mask, and Simple Network Management Protocol (SNMP).

#### **Before Configuration:**

Connection to the IBM 2216 must be through the modem or the EIA 232 service port over a serial link. While the IBM 2216 is in this state, you cannot use the Communications option of the Configuration Program. You can create configuration files and download them to the IBM 2216 over the serial link using the TFTP over SLIP. The workstation must be running TCP/IP.

#### **After Configuration:**

The configuration file that you download over a serial link can provide an IP address and subnet mask to the IBM 2216.

When the IBM 2216 is in this state, you can use the Communications Send option of the Configuration Program to send configuration files from the workstation over the network to the IBM 2216. If you are using the AIX version of the Configuration Program, you can also use the Communications Retrieve option of the Configuration Program to retrieve configuration files from the IBM 2216.

#### **Command line interface**

The command line interface is a teletypewriter (TTY) text interface that requires you to enter commands to use it. The workstation that accesses it must be either an ASCII terminal or a personal computer (PC) or other programmable workstation emulating an ASCII terminal.

The command line interface can also be accessed using Telnet over a SLIP or an in-band IP connection. The IBM 2216 can support two connections at one time if one connection is a Telnet session.

The command line interface is marked by an asterisk (\*) prompt. Refer to the *Multiprotocol Access Services Software User's Guide* for a full description of this interface.

**Important:** If you use a serial connection (either local or remote), you **must press a key** to display the asterisk prompt for the command line interface.

When you make the connection, the message:

```
Please press a key to obtain console
```

appears to remind you to do this.

#### **PCMCIA Modem**

The modem is an integrated PCMCIA modem that handles data from the IBM 2216. It provides remote connection that supports either the TTY or SLIP access.

---

## IBM 2216 Access Methods

Access to the IBM 2216 is provided to enable you to install the operational software and to configure, monitor, control, and maintain the product using software that is provided with it.

### Local and Remote Console Access

When accessing the IBM 2216 locally on a null modem cable that is attached to the EIA service port or remotely through the PCMCIA modem, use VT100 terminal emulation. Because VT100 does not define function keys above F4, edit the keyboard mapping manually as follows:

- For F6, enter the mapping (ESC)OU.
- For F9, enter the mapping (ESC)(Left square bracket)00q.

**Note:** (ESC) represents the carat symbol followed by the left square bracket. Also note that the PING done at the PCMCIA modem may take up to 2 minutes.

### System Components Used for Access to the IBM 2216

These components include the IBM 2216 hardware and the Configuration Program.

#### IBM 2216 Hardware

The IBM 2216 itself is the first system component. Once the IBM 2216 has been loaded with its operational software and has been configured, it can restart from the operational software that is stored within it. It has sufficient non-volatile storage to maintain two copies of its operational software and four copies of the configuration file for each operational software load image (8 total configuration files in data areas known as *banks*). It also possesses non-volatile storage areas for logs as well as system support data areas.

**Command Line Interface:** This interface, known as *Operator control module (OPCON)*, appears when you Telnet into the service port or when you attach an ASCII terminal or terminal emulator to the service port either locally or remotely. OPCON provides the basic console support for the IBM 2216. The services OPCON provides include:

- Login authentication.
- Displaying the status of system processes. This means that the command line interface can show you which processes of the OPCON are currently active. The OPCON processes are the functions of OPCON, for example, *Config*, which is the configuration process, and *GWCON*, which is the most frequently used monitoring process. The command *Talk 6* brings up the configuration process and the command *Talk 5* brings up the GWCON monitoring process.  
  
From the Config process you can bring up the event logging system (ELS), which displays system error messages.
- Displaying statistics including:
  - Packets forwarded
  - Memory utilization
  - Uptime
  - Last restart or reboot
  - Detailed interface error counters

- Protocol status (routing tables) and error counters
- ATM Virtual Circuit Connection statistics
- Controlling the output from a process.
- Stopping the output from a process.

Refer to the two volumes of the *Nways Multiprotocol Access Services Protocol Configuration and Monitoring Reference* for a full description of the command line interface.

### **Configuration Program**

This graphical user interface tool provides an offline application for the configuration of the IBM 2216. It is installed in a workstation that is attached to the IBM 2216 service port, either remotely or locally. Requirements for the Configuration Program are listed in “Hardware and Software Requirements for the Configuration Program” on page 2-13.

### **PCMCIA Modem**

This interface is intended for remote installation, network management, and service access to the IBM 2216. The PCMCIA modem is available in most countries. In a few countries, the modem is not available. See “Hardware Requirements” on page 2-12 for more information.

---

## **Managing the Operational and Configuration Software**

The IBM 2216 comes from the factory with its operational software loaded. However, if the operational software needs an upgrade or replacement, you have to reload it. Binary configuration files can be created using the Configuration Program. These files can be uploaded to the IBM 2216 to reconfigure it.

## **IBM 2216 Software and Configuration Change Management**

The IBM 2216 is capable of storing two copies of its operational software and four copies of configuration information for each copy of the operational software. Without interrupting the operation of the IBM 2216, you can store files in it. Changes are subsequently activated in one of the following ways: immediately, after a timed interval, or at the next restart.

Should the IBM 2216 fail when a new version of the operational software is activated, one of the backup versions can be restored.

You use the command line interface for change management operations and TFTP or XMODEM to transfer files.

---

## **File Transfer**

Table 3-1 on page 3-8 defines the ways in which you can transfer configuration files and operational software files to and from the IBM 2216.

Table 3-1. File Transfer

File Transfer Method	Type of Connection
<p><b>TFTP</b> Get command from the IBM 2216 to the workstation that has the binary configuration file, to download operational software images and configuration files to the IBM 2216. Files sent using TFTP must be binary, or the IBM 2216 cannot use them. Use the Create command of the Configuration Program to save configuration files in binary format before downloading them to the IBM 2216.</p> <p>After the IBM 2216 is operational in the network, you can use the TFTP Put command over IP to upload a file from the IBM 2216 to a workstation. The file will be uploaded in binary format. Both operational software and configuration files can be uploaded.</p> <p>Use the Read router configuration option of the Configuration Program to make an uploaded configuration file usable by the Configuration Program so that you can change some parameter values in it.</p> <p><b>Note:</b> Using TFTP Put is a way to retrieve files from the IBM 2216 if the Retrieve option of the Configuration Program is not available.</p>	<ol style="list-style-type: none"> <li>1. SLIP connection (using the TFTP Get command to download files to the IBM 2216).</li> <li>2. IP connection of operational IBM 2216 over functioning network (using the TFTP Get and Put commands to download and upload files).</li> </ol>
<p><b>Xmodem</b> in ProComm or an equivalent communications program from the workstation. This method uses ASCII terminal emulation and can download and upload files to the IBM 2216. The IBM 2216 does not have to be operational in the network to use this method. Configuration and operational files must be in binary format to be used by the IBM 2216.</p> <p><b>Note:</b> This is a second way to retrieve files from the IBM 2216 if the Retrieve option of the Configuration Program is not available.</p>	<p>Serial connection through a modem (PCMCIA or an external modem) or through a null modem.</p>
<p>The Communications Option of the <b>Configuration Program</b> (actually, the protocol for this is SNMP). This method cannot be used until the IBM 2216 is operational in the network. The files are not binary, but are in a format that is internal to the Configuration Program. This function can send configuration files to the IBM 2216 and retrieve them from the server.</p> <p><b>Note:</b> The Retrieve Option is available only in the version of the Configuration Program that runs in the AIX environment.</p>	<p>IP connection of operational IBM 2216 over functioning network.</p>

## File Transfer Using TFTP or Xmodem

Use this sequence of commands to transfer a file from a workstation or server to the IBM 2216 using TFTP. You will need to substitute your own values for the IP address and path, which are given as examples. The number of bytes received is also an example.

1. From the OPCON prompt, which is an asterisk (\*), type **talk 6** and Press **Enter**. The Config> prompt appears.
2. Type **boot** and press **Enter**. The Boot config> prompt is displayed.
3. Enter **tftp**

4. When prompted, specify the file type to TFTP, which can be one of:

- c** config
- i** image
- f** firmware
- o** other (used by service personnel)

Note that you cannot overwrite a currently active bank image.

5. When prompted, specify the IP address of the TFTP server.

6. When prompted, specify the path and file name to load.

7. When prompted, enter **Y** to confirm the transfer or anything else to exit.

The following is an example of the sequence:

```
* talk 6
Config> boot
Boot config> tftp
Please specify the file type to tftp
c - config, i - image, f - firmware, o - other> i
You have chosen an image file, specify bank to write to, A, B or F> A

You cannot overwrite Bank A image; it is currently ACTIVE

You have chosen an image file, specify bank to write to, A, B or F> B

Specify the IP address of the tftp server> 1.2.3.4
Specify the path and file name to load> /usr/mas/re11/xa.ld

Enter Y to continue, anything else to exit> Y

Transferring file...

Transfer complete; 6504322 bytes received
```

The type of file called *f* is a firmware file, which contains system diagnostics and basic utilities. Files called *Other* are types used specifically by service personnel.

If you use Xmodem, you will get similar prompts that enable you to specify the bank for the image files or the bank and the config number for the configuration files that you transfer. The interface for transferring is designed so that you cannot overwrite any ACTIVE file.

---

## How Software Files Are Managed

To help you manage operational software upgrades and configurations, the IBM 2216 has a software change management feature. This utility enables you to determine which operational software file and which configuration file is active while the IBM 2216 is running.

### How to View the Files

To use the change management tool in the command line interface to view the operational software image and the configuration files, follow these steps:

1. From the OPCON prompt, which is an asterisk (\*), type **talk 6** and press **Enter**. The Config> prompt appears.

2. Type **boot** and press **Enter**. You will see the prompt `Boot config>`.
3. Type **list** and press **Enter**. You will see a list similar to this one:

```
Boot config> list

BANK A                               BANK B
IMAGE - ACTIVE                       IMAGE - AVAIL
CONFIG 1 - ACTIVE                    CONFIG 1 - AVAIL
CONFIG 2 - AVAIL                     CONFIG 2 - AVAIL
CONFIG 3 - NONE                      CONFIG 3 - NONE
CONFIG 4 - NONE                      CONFIG 4 - NONE
```

Each bank represents one image of the operational code. The images stored in BANK A and BANK B are stored on the hard drive. The Configs represent the configuration files that are stored with each bank.

## File Status Descriptions

*IMAGE* refers to the status of the operational software and *CONFIG* refers to the status of the configuration files.

The possible *IMAGE* and *CONFIG* status:

**ACTIVE** This file is currently loaded in active memory and is running on the IBM 2216.

**Note:** The status of this file can be changed only by resetting the IBM 2216. *If a config or an image is active, it is locked and cannot be overwritten or erased.*

**AVAIL** This is a good file that can be made active.

**BROKEN** This file was damaged or was not loaded into the IBM 2216 completely.

**PENDING** This file will be loaded and become active the next time the IBM 2216 is reset.

**LOCAL** This file will become active at the next reset. This reset will cause the currently *ACTIVE* file to become *PENDING*. *LOCAL* is a status that makes a file *ACTIVE* only for one reset of the IBM 2216.

Only one bank at a time contains an *ACTIVE* image. Only one configuration file is *ACTIVE* and it must be within the *ACTIVE* bank.

## How to Reset the IBM 2216

**Attention:** A reset interrupts the function of the IBM 2216 for up to 90 seconds. Be sure that the network is prepared for the interruption.

As previously stated, *PENDING* and *LOCAL* files are not loaded into active memory until you reset the IBM 2216.

You can reset the IBM 2216 using any one of these methods:

- Press the hardware reset button.
- At the `Config only>` prompt, type **reload** and press **Enter**.

**Note:** The Config only> prompt appears when no file is active. Lack of an active file indicates that an active configuration has become corrupted or that the IBM 2216 is not configured.

- At the OPCON prompt (\*), type **reload** and press **Enter**.

## Using the Configuration Program to Manage the Configuration Files

For optimal configuration management, it is recommended that you use the Configuration Program and its configuration database to manage all your IBM 2216 configuration files.

The design of change management facilitates good control of the configuration files. Keeping the ACTIVE file and the file that is stored in the configuration database the same assures that a copy of the ACTIVE file is always available.

When you use the Send option to send a new configuration to the IBM 2216, the new configuration is written to the ACTIVE bank and overwrites the file located in the position just below the currently ACTIVE configuration. The new configuration is PENDING if a time is set for a reset. If the configuration file is sent without a specified time for the reset to occur, it gets AVAIL status.

For example, suppose that CONFIG 2 is ACTIVE. The new configuration file is written to CONFIG 3. It has a status of PENDING if a reset time is associated with it; if not, it has a status of AVAIL.

If the file has a status of PENDING, CONFIG 2 becomes AVAIL and CONFIG 3 becomes ACTIVE when a reset occurs. The next file that is sent from the Configuration Program will be placed in CONFIG 4. If a reset time is associated with the file, it will have the PENDING status and will become ACTIVE when the next reset occurs. If another file is then sent, it is placed in CONFIG 1 because the currently ACTIVE file is now in CONFIG 4. This arrangement results in a circular queue.

If the downloaded file has a status of AVAIL, a reset does not change its status. If another file is sent down, it overwrites that file because the ACTIVE file has not changed and the newly downloaded file always occupies the location just behind the ACTIVE file.

### Example of Sending a File from the Configuration Program

For example, suppose that this is the view of the software that is displayed by the List command:

BANK A	BANK B
IMAGE - ACTIVE	IMAGE - AVAIL
CONFIG 1 - ACTIVE	CONFIG 1 - AVAIL
CONFIG 2 - AVAIL	CONFIG 2 - AVAIL
CONFIG 3 - NONE	CONFIG 3 - AVAIL
CONFIG 4 - NONE	CONFIG 4 - NONE

The Configuration Program sends a config file to BANK A, CONFIG 2. If the configuration is marked in the Configuration Program to be loaded immediately, the IBM 2216 performs a reset immediately after it received the new configuration. The Send command of the Configuration Program in this situation is composed of these two actions:

1. Send Config to CONFIG 2 as PENDING
2. Reset

After these two actions, the IBM 2216 configuration looks like this:

```
Boot Config> list
```

BANK A	BANK B
IMAGE - ACTIVE	IMAGE - AVAIL
CONFIG 1 - AVAIL	CONFIG 1 - AVAIL
CONFIG 2 - ACTIVE	CONFIG 2 - AVAIL
CONFIG 3 - NONE	CONFIG 3 - AVAIL
CONFIG 4 - NONE	CONFIG 4 - NONE

CONFIG 1 has become AVAIL and CONFIG 2 has become ACTIVE.

If the Configuration Program were now used to send down a new configuration to the IBM 2216 and the file were not marked to be loaded at any specified time, the view of the software in the IBM 2216 would look like this:

```
Boot Config> list
```

BANK A	BANK B
IMAGE - ACTIVE	IMAGE - AVAIL
CONFIG 1 - AVAIL	CONFIG 1 - AVAIL
CONFIG 2 - ACTIVE	CONFIG 2 - AVAIL
CONFIG 3 - AVAIL	CONFIG 3 - AVAIL
CONFIG 4 - NONE	CONFIG 4 - NONE

After this action, CONFIG 3 is AVAIL. The new configuration file has been loaded in this location.

**Note:** You should exercise caution here because any on-board configuration changes could result in overwriting the CONFIG 3 file. Because the configuration file in CONFIG 3 was sent down without any time specified for resetting the server, it is currently not in use. It can be overwritten either when another file is sent from the Configuration Program or when a file is saved using the Write command from the command line interface. You can use the Copy command to move it to another location to protect it (see “Using the Copy Command” on page 3-16).

## Using the Set Commands

**Note:** You must be the supervisory user to use the Set commands.

The Set commands allow you to perform the following tasks:

- Set active load image
- Set active configuration
- Set boot list
- Set serial port settings
- Set power-on password
- Set supervisory password
- Set enable unattended mode
- Set disable unattended mode
- Set time and date



## Set Active Load Image

To make an image file PENDING, type **set load image** or **set load** at the Boot config> prompt.

This command will display the current settings for load as the list command did. However, you can change the setting of an AVAIL file to PENDING. After a file is PENDING, it will be changed to ACTIVE when the IBM 2216 is next reset. After the reset, the current ACTIVE file becomes AVAIL.

```
Boot Config> set load
```

```
BANK A                                BANK B
IMAGE - ACTIVE                        IMAGE - AVAIL
CONFIG 1 - ACTIVE                     CONFIG 1 - AVAIL
CONFIG 2 - AVAIL                      CONFIG 2 - AVAIL
CONFIG 3 - NONE                       CONFIG 3 - NONE
CONFIG 4 - NONE                       CONFIG 4 - NONE
```

You may type 'e' at any prompt to exit this command

Please specify the bank to load from (A or B).

```
BANK A                                BANK B
IMAGE - ACTIVE                        IMAGE - AVAIL
CONFIG 1 - ACTIVE                     CONFIG 1 - AVAIL
CONFIG 2 - AVAIL                      CONFIG 2 - AVAIL
CONFIG 3 - NONE                       CONFIG 3 - NONE
CONFIG 4 - NONE                       CONFIG 4 - NONE
```

You will need to restart the IBM 2216 for these changes to take effect.

## Set Active Configuration

This command will display the current settings for load as the List command did. However, you can change the current setting of a configuration file that is in an ACTIVE or PENDING bank from AVAIL to PENDING.

To use the Set active configuration command, type **set config image** or **set config** at the Boot config> prompt and follow the prompts.

## Set Boot List

This command will set up the order of the boot devices when the IBM 2216 is loading. Typically you will set this up once and not change it unless the hardware features installed in the IBM 2216 are changed.

**Note:** This is the default order of the boot devices:

1. Hard disk
2. PCMCIA modem
3. Serial port (service port)

Refer to the *IBM 2216 Maintenance Guide*, SY27-0350 for information about booting from the PCMCIA modem or the serial port.

```

Boot Config> set boot list
DEVICE  DEVICE          BOOT
NUM    DESCRIPTION      ORDER
  1    HARD DISK        1
  2    PCMCIA MODEM (SLIP)  0
  3    SERIAL PORT (SLIP)  0

```

Please specify the first boot device 1, 2 or 3>2

Please specify the second boot device 1, 2 or 3>1

Please specify the third boot device 1, 2 or 3>1

The current boot order has been changed to:

```

DEVICE  DEVICE          BOOT
NUM    DESCRIPTION      ORDER
  1    HARD DISK        2
  2    PCMCIA MODEM (SLIP)  1
  3    SERIAL PORT (SLIP)  0

```

Please enter Y to commit changes, anything else to exit>y

Boot list changed

### Set Serial Port

This command enables you to change the serial port parameters in regard to speed, parity, data bits, and stop bits.

```

Boot config> set serial
CURRENT SETTINGS:
PORTS   SPEED   DATA   PARITY   STOP
SERIAL  19200   8       NONE     1

```

Available speeds are 19 200, 9600, 4800, 2400

Please enter the speed for serial port> 19 200

Please enter the number of data bits 7 or 8> 8

Please enter the parity, even, odd or none> none

Please enter the number of stop bits 1 or 2> 1

```

PROPOSED SETTINGS
PORTS   SPEED   DATA   PARITY   STOP
SERIAL  19200   8       NONE     1

```

Please enter Y to commit changes, anything else to cancel> n

Your changes have been canceled

## Other Change Management Functions

These are the other change management commands:

- Describe load images
- Describe config images
- Disable dumping
- Enable dumping
- Erase files

### Describe Load Images

At Boot `config>`, type **describe 2216**. The Product ID, microcode version number, release number, maintenance number, PTF, Feature, and RPQ numbers and the date of the operational software image are displayed.

### Describe Config Images

At Boot `config>`, type **describe config**. For each configuration file that is loaded, its bank, internal location (for example, CONFIG 1), version, and level is displayed.

### Disable Dumping

The IBM 2216 can be set up to dump the contents of memory to permanent storage in the unlikely event of a complete system failure. If dumping is enabled, using this selection will cause the IBM 2216 *not* to dump to disk.

To disable dumping, type **talk 6** or **t 6** at the \* prompt, press **Enter**, and then type **disable dump memory** or **dis dump** at the `Config>` prompt. You will see the message:

```
System memory dump function disabled successfully.
```

### Enable Dumping

This command enables the dumping of memory without intervention from anyone in the event that the IBM 2216 has a catastrophic error. The IBM 2216 will dump memory onto the hard disk. Once a successful dump has been taken, the IBM 2216 attempts to restart. Depending upon the failure of the IBM 2216, it cannot always restart. In this case, you should restart it manually and call a service person who will dial into the IBM 2216 to determine the nature and the causes of the failure.

Before you may enable dumping you must first enable system rebooting. To enable system rebooting, enter the following commands at the `Config>` prompt.

```
enable reboot-system  
enable dump-memory
```

Finally, to enable dumping, type **t 6** at the \* prompt, press **Enter**, and then type **enable** or **ena** at the `Config>` prompt. You will see the message:

```
System memory function enabled successfully
```

The default state is to have dumping enabled.

## Erase Files

The IBM 2216 has a DOS file system structure with user access files in the /sys0 and /sys1 banks. The contents of these banks are the operational software load images and the configuration files. Note that the following rules apply to erasing files from the IBM 2216:

- Image files that are not ACTIVE can be overwritten anytime
- ACTIVE image files **cannot** be erased
- ACTIVE configuration files **cannot** be erased

To erase a file, at the `Boot config>` prompt, type **erase**. Follow the prompts. If you select a file to erase that is BROKEN or NONE, the erase option is discontinued.

## Using the Copy Command

The Copy command allows you to move a file from one location in the storage area to another. This command allows you to change the status as well. The file that you move always receives the status of the storage area that it is moved to. For example, suppose that you have this scenario:

- The configuration file in BANK A CONFIG 1 is AVAIL. The configuration file in BANK B CONFIG 1 is PENDING.
- You copy the configuration in BANK A CONFIG 1 to BANK B CONFIG 1.

In this case, the original configuration file in BANK A CONFIG 1 remains unchanged and AVAIL. The configuration that was in BANK B CONFIG 1 is overwritten by a copy of the configuration file that is in BANK A CONFIG 1. This copy retains the status of the file that it overwrote, in this case, PENDING.

These are the prompts that you would use to perform this copy process.

```
Boot config> copy config
```

```
Copy FROM Bank number? A
```

```
Copy FROM Config number? 1
```

```
Copy TO Bank number? B
```

```
Copy TO Config number? 1
```

If you copy an image, the same rules apply except that image files can be copied only from Bank to Bank. These steps describe how the copy of an image affects the image that was previously in the Bank:

1. The copy overwrites the image that was previously in the Bank.
2. The copy acquires the status of the image that was previously in the Bank.

---

## Chapter 4. Completing Worksheets

This chapter explains how to prepare the worksheets in Appendix C, "Charts and Worksheets" on page C-1 prior to making your IBM 2216 operational. These charts and worksheets are useful in helping your network installer complete the installation.

These charts and worksheets should be completed by the network planner or network administrator.

You are authorized to make as many copies of these charts and worksheets as you need to plan your network. Save the blank originals for future copies.

---

### Hardware Configuration Quick Reference

This fanfold card (GX27-3988) is shipped separately with each IBM 2216. Part of the setup procedure (in the *Hardware Installation Guide*) is to fill out this card, which when completed will describe how your 2216 is configured and cabled.

The *IBM 2216 Hardware Configuration Quick Reference* card is an ongoing record of the connections made to the 2216 port receptacles. In addition, the chart records the location of the 2216 and the number of the ring or segment to which it attaches. The card is used during installation and cabling of the 2216 and while performing problem determination procedures.

---

### The Rack Inventory Chart

The Rack Inventory Chart (in Appendix C, "Charts and Worksheets" on page C-1) allows you to keep track of all components installed in each rack in your site to facilitate planning and installation.

Fill out a Rack Inventory Chart for each of the racks where you will be installing 2216s. Mark the location of each 2216 on the chart using the scaled template provided. Write the unit number and device type of each component directly on the chart.

Give the filled-out chart to the individual who will install the 2216 in your network.

---

### Initial Configuration Worksheet

You must be at the `Config (only)>` prompt to perform initial configuration on the 2216. You must add each device (port) that you will be using. Make 1 copy of page C-6 for each device you will be adding.

The syntax for the Add command is as follows:

```
Config (only)> Add Device Token-Ring 1 1
```

The example above of the Add Device command applies to adding an interface on a multi-port adapter. If you add an interface on a single-port adapter, then you merely provide the slot number. If you add a dial circuit device, then you enter **add device dial-circuit**. See the *Multiprotocol Access Services Software User's Guide*.

---

## Quick Configuration Worksheet

Use Quick Configuration to configure bridging and protocols for the devices. You can access Quick Configuration by typing **QC** at the `Config (only)>` prompt. Use the Quick configuration worksheets to help you complete the configuration.

---

## Token-Ring Configuration Worksheet

Refer to the chapter entitled “Configuring IEEE 802.5 Token-Ring Network Interfaces” in the *Multiprotocol Access Services Software User’s Guide*. You must be at the `TKR config>` prompt to perform a Token-Ring Configuration † indicates default values; an unchecked box indicates you should skip that step.

---

## Chapter 5. Quick Configuration

Following hardware setup as described in *Hardware Installation Guide*, you will need to perform a “Quick Configuration.” This chapter tells you how. To connect a terminal to your IBM 2216, see Chapter 3, “Accessing and Managing the IBM 2216.”

Before starting the Quick Configuration process, read these notes:

- 1** You must attach an ASCII terminal to the service port to run the Quick Configuration program. See Chapter 3, “Accessing and Managing the IBM 2216.”
- 2** Any existing configuration for a particular item will be removed if that item is configured through Quick Configuration.
- 3** Configuration is done at the level of the *interface*, which corresponds to a single *port* on an adapter. Because different types of adapters have differing numbers of ports, you may have to configure up to eight ports to activate all of the interfaces on the adapter (in the case of the X.21 adapter FC 2291, for example).
- 4** Using the Add Device command, you must “add” all desired network interfaces for the adapters installed in your IBM 2216. This must be done prior to running Quick Configuration. To add an interface, see “Adding an Adapter at Initial Configuration” on page B-3 or the *Software User’s Guide*.
- 5** Information shown in brackets, [ ], is the default. To use the default, press **Enter**. To use a value other than the default, choose from the values in the parentheses. If no value appears in the brackets, there is no default and you must type a value.
- 6** To restart the current Quick Configuration section at any time, type **r**. For example, if you are in the Bridging Configuration section, type **r** and press **Enter** to return to the beginning of that section.
- 7** To exit Quick Configuration, type **q** and press **Enter**. The Config> prompt will appear.
- 8** To start or restart Quick Configuration from the Config> or Config (only)> prompt: type **qc** and press **Enter**.
- 9** When you have completed your configuration, you must restart the IBM 2216 for the configuration to take effect. At the end of the Quick Configuration program, you are given that option.

## Configuring the IBM 2216 Using Quick Configuration Sample

The following sections cover a sample configuration of the IBM 2216 using the Quick Configuration program. The program displays the following panel after starting:

```
No Protocols Configured. Entering Quick Config

Router Quick Configuration for the following:

o Bridging
    Spanning Tree Bridge (STB)
    Source Routing Bridge (SRB)
    Source Routing/Transparent Bridge (SR/TB)

o Protocols
    IP (including OSPF, RIP)
    IPX
    DNA (DECnet)

Event Logging will be enabled for all configured subsystems
with logging level 'Standard'
```

Event logging records system activity, status changes, data transmission and reception, data and internal errors, and service requests. The logging level is set to standard (the default). For more information about error logging, refer to the *Event Logging System Messages Guide*.

During Quick Configuration you will:

- 1 Configure bridging
- 2 Configure protocols
- 3 Enable Console Modem-Control
- 4 Restart the 2216

## Configuring Bridging

```
*****
Bridging Configuration
*****

Type 'Yes' to Configure Bridging
Type 'No' to skip Bridging Configuration
Type 'Quit' to exit Quick Config

Configure Bridging? (Yes, No, Quit): [Yes]
```

- 1 Take one of the following actions:
  - Enter **y** to display the bridging configuration prompts. The prompts that appear depend on your network configuration.
  - Enter **n** to skip the bridging configuration and continue with quick configuration.
  - Enter **q** to exit quick configuration. This displays the Config> prompt. To reenter quick configuration, enter **qc** after this prompt.



```
Type 'r' any time at this level to restart Bridging Configuration
```

```
STB will be enabled on all LAN interfaces
```

- 2** Enter **y** after each prompt to enable STB on the interface. Otherwise, enter **n**.

```
Configure SRT Bridging? (Yes, No): [Yes]
You are now configuring the Source Routing part of SRT Bridging
Bridge Number (hex) of this Router (0-F): [A]
```

- 3** Bridge number is a hexadecimal value from 0 to F that is unique between two parallel segments.

```
Interface 0 (Port 1) is of type Token Ring
Configure Source Routing on this interface (Yes, No): [Yes]
```

- 4** Enter **y** to configure source routing on the interface. The console displays the following two lines.

```
Configuring Interface 0 (Port 1)
Segment Number (hex) of this Interface (1-FFF): [A1]
```

**Note:** The port number is 1 for interface 0 because source routing bridging port numbers start at 1.

A unique hexadecimal value from 1 to FFF is assigned to each interface. The interfaces on each ring (segment) have the same segment number, but the segment number is unique to each ring.

```
Interface 1 (Port 2) is of type Token Ring
Configure Source Routing on this interface? (Yes, No): [Yes]
Configuring Interface 1 (Port 2)
Segment Number (hex) of this Interface (1-FFF): [A2]
```

**5** A panel similar to the following one is displayed:

```
This is all configured bridging information:

  Interfaces configured for STB:

  Interface #   Port #   Interface Type
          0       1       Token Ring
          1       2       Token Ring

The Source Routing part of SRT Bridging has been enabled

Bridge Number of this Router: A

Interfaces configured for Source Routing:

  Interface #   Port#   Segment #   Interface Type
          0       1       A1         Token Ring
          1       2       A2         Token Ring

Save this Configuration? (Yes, No): [Yes]
```

**6** Enter **y** to save the bridging configuration and continue with quick configuration. Enter **n** to redisplay the bridging configuration prompts.

```
Bridging configuration saved
```

## Configuring Protocols

After you save the bridging configuration, you will see the following panel:

```
*****
Protocol Configuration
*****

Type 'Yes' to Configure Protocols
Type 'No' to skip Protocol Configuration
Type 'Quit' to exit Quick Config

Configure Protocols? (Yes, No, Quit): [Yes]
```

Enter **y** to configure the protocols. Enter **n** to skip protocol configuration and continue with quick configuration. Enter **q** to exit quick configuration.

You will first configure IP, then IPX, and then DECnet.

## Configuring IP

When you reply **y** to the Configure Protocols prompt, quick configuration displays the following messages:

```
Type 'r' any time at this level to restart Protocol configuration
Configure IP? (Yes, No): [Yes]
```

- 1 Enter **y** to configure IP. Enter **n** to skip IP configuration and continue with quick configuration.

You will see messages similar to the following messages:

```
Type 'r' any time at this level to restart IP configuration.
```

```
Configuring Per-Interface IP Information
Configuring Interface 0 (Token Ring)
Configure IP on this interface? (Yes, No): [Yes]
IP Address: [ ] 192.1.1.8
Address Mask: [255.255.255.0]
```

The preceding lines appear for each interface.

- 2 Enter the IP address in decimal notation for example, 128.185.142.20. The console displays one of the following error messages if you enter an invalid IP address:

```
Bad address, please try again.
```

```
This address has already been assigned. Enter a different address
```

```
Address mask is a decimal value that reflects the IP network or subnetwork to
which this interface is attached.
```

For more information about IP addressing or address masks, refer to *Protocol Configuration and Monitoring Reference* or consult your network administrator.

```
Per-Interface IP Configuration complete
Configuring IP Routing Information
Enable Dynamic Routing (Yes, No): [Yes]
```

- 3 Enter **y** if you want the routing protocols (RIP or OSPF) to build the routing tables. Enter **n** to manually add IP address destinations to the routing tables (static routes).

```
Enable OSPF? (Yes, No): [Yes]
```

- 4 Enter **y** to enable the OSPF routing protocol as the primary dynamic IP routing protocol. RIP will be enabled only to send advertisements, not to receive them. Enter **n** if you do not want to use OSPF. RIP will be enabled to send and receive advertisements.

```
OSPF Enabled with Max routes = 1000 and Max routers = 50
```

Max routes is the maximum number of autonomous system (AS) external routes imported into the OSPF routing domain. Max routers is the maximum number of OSPF routers in the routing domain.

```
Routing Configuration Complete
```

```
SNMP will be configured with the following parameters:
```

```
Community: public  
Access: read_trap
```

```
This is the information you have entered:
```

Interface #	IP Address	Address Mask
0	192.1.1.8	255.255.255.0
1	192.1.2.8	255.255.255.0
2	192.2.1.8	255.255.255.0
3	192.3.1.8	255.255.255.0

```
OSPF is configured, and RIP is configured only for 'sending'
```

```
Save this configuration? (Yes, No): [Yes]
```

- 5** Enter **y** to save the IP configuration and continue with quick configuration.  
Enter **n** to redisplay the protocol configuration prompts.

## Configuring IPX

After you save the IP configuration, you will see the following messages:

```
IP configuration saved
Configure IPX? (Yes, No): [Yes]
```

- 1** Enter **y** to configure IPX. Enter **n** to skip IPX configuration and continue with quick configuration.

You will see messages similar to the following messages:

```
Type 'r' any time at this level to restart IPX Configuration
```

```
IPX Configuration is already present
Configure IPX anyway? (Yes, No): [No] yes
```

- 2** Enter **y** to replace the existing configuration. Enter **n** to keep the current configuration and continue.

```
.
Configuring Per-Interface IPX Information
Configuring Interface 0 (Token Ring)
Configure IPX on this interface? (Yes, No): [Yes]
```

- 3** The next messages and your responses depend on whether you are configuring a Token-Ring or an Ethernet adapter.

### Token-Ring

- a** The following prompt is displayed:

```
Token Ring encapsulation (frame) type? (TOKEN-RING MSB, TOKEN-RING LSB,
TOKEN-RING_SNAP MSB, TOKEN-RING_SNAP LSB): [TOKEN-RING MSB]
```

- b** Enter the encapsulation type used by the IPX protocol on your Token-Ring end stations.

Token-Ring MSB:	Most common encapsulation type and the default. The IBM 2216 builds outgoing packets with a 3-byte 802.2 header, (0xE0, 0xE0, 0x03). It sends the source and destination addresses in MSB (most significant bit), or noncanonical, format, which is the native address format for Token-Ring.
Token-Ring LSB	Same as Token-Ring MSB except the IBM 2216 sends the addresses in LSB (least significant bit), or canonical, format.
Token-Ring SNAP MSB	The IBM 2216 builds outgoing packets with an 8-byte 802.2/SNAP header (0xAA, 0xAA, 0x03, 0x00, 0x00, 0x00, 0x81, 0x37). It sends the source and destination addresses in most significant bit (MSB), or noncanonical, format.
Token-Ring SNAP LSB	Same as Token-Ring SNAP MSB except the IBM 2216 sends the addresses in LSB, or canonical, format.

## Ethernet

**a** The following prompt is displayed:

```
Ethernet encapsulation type? (ETHERNET_8022, ETHERNET_8023, ETHERNET_ii,
ETHERNET_SNAP): [ETHERNET_8023]
```

**b** Enter the encapsulation type used by the IPX protocol on your Ethernet end stations.

Ethernet_8022	Packet includes an 802.2 header. This is the default for NetWare Versions 4.0 and higher.
Ethernet_8023	Uses an IEEE 802.3 packet format without the 802.2 header. This is the default and the default for NetWare versions prior to 4.0. Ethernet 802.3 does not conform to the IEEE 802 standards because it does not include an 802.2 header. It may cause problems with other nodes on the network.
Ethernet_II	Uses Ethernet type 8137 as the packet format. This format is required if you are using NetWare VMS on the Ethernet.
Ethernet_SNAP	Uses the 802.2 format with a SNAP header. This encapsulation type is meant to be compatible with token-ring SNAP encapsulation. However, it violates IEEE standards and is not interoperable across IEEE-compliant bridges.

```
Network Number (hex) (1-FFFFFFFE):[] 1
Enable IPXWAN? (Yes, No): [No]
```

**4** Assigns an IPX network number to the associated directly connected network. Every IPX interface must have a unique network number.

```

Configuring Interface 1 (WAN PPP)
Configure IPX on this interface? (Yes, No): [Yes]
Network Number (hex) (1-FFFFFFE): [1] 2

Enable IPXWAN? (Yes, No): [No] yes

Configuring Interface 2 (WAN PPP)
Configure IPX on this interface? (Yes, No): [Yes]
Network Number (hex) (1-FFFFFFE):[1] 3

Enable IPXWAN? (Yes, No): [No] yes

Host Number for Serial Lines: (000000000000) 1

Configure IPXWAN NodeID? (Yes, No): [Yes]
NodeID (hex) (1 - FFFFFFFE): [1] 4

```

If enabled, the IPXWAN protocol negotiates routing parameters to be used on the PPP serial interface before IPX packet forwarding begins. IPXWAN is not required to forward IPX packets on PPP serial interfaces. The IPXWAN Node ID is a unique IPX network number that identifies the router, and is required if IPXWAN is enabled on any network interfaces.

- Host number is a unique 12-digit hexadecimal value assigned to an IPX router. It is required because serial lines do not have hardware node addresses from which to build a host number.

```

This is the information you have entered:

                Per-Interface Configuration Information

Ifc  IPX Net (hex)  Encapsulation  IPXWAN
0    1             TOKEN-RING MSB  Not Configured
1    2                                 Enabled
2    3                                 Enabled

Host Number for Serial Lines: 000000000001
IPXWAN Node ID = 4
IPX Router Name = ipx_router-4

Save this configuration? (Yes, No): [Yes]

```

- Enter **y** to save the IPX configuration and continue with quick configuration. Enter **n** to redisplay the IPX configuration prompts.

```
IPX configuration saved
```

## Configuring DECnet (DNA)

After you save the IPX configuration, you will see the following messages.

```

IPX Configuration saved

Configure DNA? (Yes, No): [Yes]

```

- Enter **y** to configure DNA. Enter **n** to skip DNA configuration and continue with quick configuration.

```

Type 'r' any time at this level to restart DNA Configuration

Configuring Global DNA information

Highest Node Number (decimal) (1-1023): [32]
Router Level (Level1, Level2, DEC Level1, DEC Level2):
 [ Level2]
Highest Area (decimal) (1-63): [63]
Node Address (area.node): (63.32)

```

**2** The above configuration fields are configured with the following considerations.

### Highest Node Number

Is the highest node address in the router's area. Setting it excessively high will affect the router's efficiency and require excess storage.

### Router Level

Identifies whether the router is a Level 1 or Level 2 router. A Level 1 router keeps track of all nodes in its area and does not care about nodes outside its area. A Level 2 router routes traffic between areas. Normally you should select Level1 or Level2 with the following exception. Select DEC Level1 or DEC Level2 only when this router must communicate over X.25 networks with routers conforming to the DEC X.25 standard.

### Highest Area

This number should be at least as high as the highest area number in the overall network.

### Node Address

Is the node ID of this router and must be unique in the network.

```

Configuring Per-Interface DNA Information

Configuring Max Routers on each interface

Configuring Interface 0 (Ethernet)
Configure DNA on this interface? (Yes, No) [YES]
Max Routers (decimal) (1-33): [16]

Configuring Interface 1 (WAN PPP)
Configure DNA on this interface? (Yes, No) [Yes]

Configuring Interface 2 (Token Ring)
Configure DNA on this interface? (Yes, No) [Yes]
Max Routers (decimal) (1-33): [16]

```

**3** Enter **y** for every interface that will be connected to the DECnet network. For LANs, Max Routers specifies how many other routers can be on this circuit. For router efficiency and memory requirements, set this argument to a few more than the total number of adjacent routers on this circuit.

**4** The following panel is displayed:



```
This is the information you have entered:

Global Configuration Information

Highest Node Number:      32
Router Level:             Level2
Highest Area:             63
Node Address:             63.32

Pre-Interface Configuration Information
Interface Number          Max Routers

      0                    16
      1                    1
      2                    16

Save this configuration? (Yes, No): [Yes]
```

**5** Enter **y** to save the DECnet configuration and continue with the quick configuration. Enter **n** to redisplay the DECnet configuration prompts.

```
DNA Configuration Saved
```

### Restarting the IBM 2216

After configuring the protocols, you will receive the following message:

```
Quick Config Done
Do you want to write this configuration? (Yes, No): [Yes]
```

Enter **y** to save your changes and display the following information:

```
Default config file written successfully.

Configuration was written.
The system must be restarted for this configuration to take effect.
```

Enter **restart** after the Config> prompt to restart the IBM 2216 with the new configuration. To change or view the current configuration, enter **qc**.

---

## Full Configuration

The Quick Configuration procedure you have just performed will enable you to access the IBM 2216 over the network, if you have configured an IP address for it.

The configuration provided by QCONFIG depends upon many default values for parameters, some of which may not be appropriate to your installation. You may need to modify the configuration that you have created using QCONFIG to customize the IBM 2216 to work on your network. You can do this using either of these methods:

- Configuration Program
- Command line interface (OPCON)

However, the Configuration Program is the preferred configuration method for these reasons:

- 1** It can enable you to keep a number of copies of configuration files on a server for uploading to the appropriate IBM 2216s.
- 2** It does not alter any configuration parameters dynamically. This feature helps you control changes to the IBM 2216 configurations.
- 3** It performs more input validation and cross-checking of the configuration parameters than the other methods.

The command line interface causes certain parameters to be altered dynamically. The binary files that they create are saved on the hard disk of the IBM 2216, not in the workstation. These characteristics make them more difficult to use for managing the configuration of the IBM 2216. However, they can be used to monitor the operations of the IBM 2216, whereas the Configuration Program cannot. They are also useful when you want to change one of the parameters that can be dynamically altered. For more information, refer to the *Software User's Guide* and the *Configuration Program User's Guide* in order to complete the configuration.

---

## Appendix A. Cable Specifications

This appendix describes the signals associated with the pins on the cable connectors for the service port and the WANs supported by the 2216 for customer-unique applications.

LAN and ISDN ports use industry-standard cables. Contact your cable supplier for more information.

---

### Service Port

The service port provides an EIA 232/V.24-compatible DTE interface on a 9-pin male D-connector with the following signal definitions:

*Table A-1. Service Port Signal Definitions*

Pin No.	Signal	Driven by 2216	Received by 2216
1	Carrier Detect		x
2	Receive Data		x
3	Transmit Data	x	
4	Data Terminal Ready	x	
5	Ground		
6	Data Set Ready		x
7	Request To Send	x	
8	Clear To Send		x
9	Ring Indicate		x

A null modem adapter, supplied with the IBM 2216, is required for attachment to a terminal having a male connector.

---

### Wide Area Networks (WANs)

The cables that IBM ships for the IBM 2216 are described in this section.

If you need special cables with specific lengths, use the information in this section to specify the assignment for the pins. The following list gives the conformity for the EIA and CCITT connectors:

- EIA 232-D/CCITT V.24 connector must conform to ISO 2110.2
- CCITT V.35 connector must conform to ISO 2593
- CCITT V.36 connector must conform to ISO 4902
- CCITT X.21 connector must conform to ISO 4903

Bulk cable consists of the appropriate numbers of 28 American Wire Gauge (AWG) tin-plated copper individually-shielded pairs, with an overall shield. The nominal characteristic impedance of the bulk cable should be 85 ohms. The cable should meet the safety requirements of the appropriate local safety organization.

The length of the connection from the 2216 to the attaching equipment should not exceed 15 m (50 ft).

The wiring of these cables is shown in the following tables.

## **Disclaimer**

The information in this chapter does not guarantee function or compliance with radio frequency interference (RFI) or electromagnetic interference (EMI) regulations.

## EIA 232-E/V.24 (FC 2705 and 2706)

Table A-2. EIA 232/V.24 Connector Pin Assignments, 25-pin D, Male, Modem-Attach

Signal	Machine End Pin Number	DCE End Pin Number
Protective Ground	1	1
Transmitted Data	2	2
Signal Ground	7	7
Received Data	3	3
Data Set Ready	6	6
DCE Transmitter Signal Element Timing	15	15
Receiver Signal Element Timing	17	17
Clear To Send	5	5
Local Loopback	18	18
Ring Indicate	22	22
Data Terminal Ready	20	20
Request To Send	4	4
Received Line Signal Element	24	8
DTE Transmitter Signal Element Timing	24	24
Data Signal Rate Selector	23	23

Table A-3. EIA 232/V.24 Connector Pin Assignments, 25-pin, D, Female, Direct-Attach

Signal	Machine End Pin Number	DTE End Pin Number	Signal
Send Data	2	3	Received Data
Signal Ground	7	7	Signal Ground
Received Data	3	2	Transmitted Data
Data Set Ready	6	20	Data Terminal Ready
Transmit Clock	15	24	DTE Transmitter Signal Element Timing
Receive Clock	17	24	Receiver Signal Element Timing
Clear To Send	5	8	Received Line Signal Detect
Data Terminal Ready	20	6	Data Set Ready
Request To Send	4	8	Received Line Signal Detect
Received Line Signal Detect	8	5	Clear to Send
Received Line Signal Detect	8	4	Request to Send
DTE Transmitter Signal Element Timing	24	15 17	DCE Transmitter Signal Element Timing Receiver Signal Element Timing

## V.35 (FC 2707 and 2708)

Table A-4. V.35 Connector Pin Assignments, 34-pin Block, Male, Modem-Attach

<b>Signal</b>	<b>Machine End 25-Pin Con- nector Pin Number</b>	<b>DCE End Pin Number</b>
Transmitted Data (A)	2	P
Transmitted Data (B)	14	S
Received Data (A)	3	R
Received Data (B)	16	T
Receive Timing (A)	17	V
Receive Timing (B)	9	X
Transmit Timing (A)	15	Y
Transmit Timing (B)	12	AA
Terminal Timing (A)	24	U
Terminal Timing (B)	11	W
Signal Ground	7	B
Request To Send	4	C
Clear to Send	5	D
Receive Line Signal Detect	8	F
Data Terminal Ready	20	H
Data Set Ready	6	E

Table A-5. V.35 Connector Pin Assignments, 34-pin Block, Female, Direct-Attach

<b>Signal</b>	<b>Machine End 25-Pin Connector Pin Number</b>	<b>Machine End Pin Number</b>	<b>Signal</b>
Transmit Data (A)	2	R	Receive Data (A)
Transmit Data (B)	14	T	Receive Data (B)
Receive Data (A)	3	P	Transmit Data (A)
Receive Data (B)	16	S	Transmit Data (B)
Shield	1	A	Shield
Signal Ground	7	B	Signal Ground
Receive Line Signal Detect	8	C	Request to Send
Receive Line Signal Detect	8	D	Clear to Send
Request to Send	4	F	Receive Line Signal Detect
Clear to Send	5	F	Receive Line Signal Detect
Data Set Ready	6	E	Data Set Ready
Data Terminal Ready	20	E	Data Set Ready
Transmit Clock In (A)	15	U	Terminal Timing (A)
Receive Clock In (A)	15	U	Terminal Timing (A)
Receive Clock In (B)	17	U	Terminal Timing (A)
Transmit Clock In (B)	12	W.	Terminal Timing (B)
Terminal Timing (A)	24	Y	Transmit Clock In (A)
Terminal Timing (A)	24	V	Receive Clock In (A)
Terminal Timing (B)	11	X	Receive Clock In (B)
Terminal Timing (B)	11	AA	Transmit Clock In (B)

## V.36 (FC 2709 and 2710)

Table A-6. V.36 Connector Pin Assignments, 37-pin D, Female to Female, Modem-Attach

Signal	Machine End Pin Number	DCE End Pin Number	
Transmit Data (A)	4	6	Receive Data (A)
Transmit Data (B)	22	24	Receive Data (B)
Receive Data (A)	6	4	Transmit Data (A)
Receive Data (B)	24	22	Transmit Data (B)
Transmit Clock out (A)	17	5	Transmit Clock in (A)
		8	Receive Clock in (A)
Transmit Clock out (B)	35	23	Transmit Clock in (B)
		26	Receive Clock in (B)
Transmit Clock in (A)	5	17	Transmit Clock out (A)
Receive Clock in (A)	8		
Transmit Clock in (B)	23	35	Transmit Clock out (B)
Receive Clock in (B)	26		
Data Set Ready	11	11	Data Set Ready
Data Terminal Ready	12		
Receive Line Signal Detect	13	7	Request to Send
		9	Clear to Send
Request to Send	7	13	Receive Line Signal Detect
Clear to Send	9		
Signal Ground	19	19	Signal Ground
DCE Signal Ground	20	37	DTE Signal Ground
DTE Signal Ground	37	20	DCE Signal Ground



Table A-7. V.36 Connector Pin Assignments, 37-pin D, Female to Male, Direct-Attach

<b>Signal</b>	<b>Machine End Pin Number</b>	<b>DTE End Pin Number</b>
Transmit Data (A)	4	4
Transmit Data (B)	22	22
Receive Data (A)	6	6
Receive Data (B)	24	24
Send Timing (A)	5	5
Send Timing (B)	23	23
Receive Timing (A)	8	8
Receive Timing (B)	26	26
Terminal Timing (A)	17	17
Terminal Timing (B)	35	35
Data Set Ready	11	11
Data Terminal Ready	12	12
Receive Line Signal Detect	13	13
Request to Send	7	7
Clear to Send	9	9
Signal Ground	20	20
Signal Ground	19	19
Signal Ground	37	37

## X.21 (FC 2711 and 2712)

Table A-8. X.21 Connector Pin Assignments, 15-pin D, Male

Signal	Machine End Pin Number	DCE End Pin Number
Transmit (A)	2	2
Transmit (B)	9	9
Control (A)	3	3
Control (B)	10	10
Indicate (A)	5	5
Indicate (B)	12	12
Signal Element Timing (A)	6	6
Signal Element Timing (B)	13	13
DTE Transmit Signal Element Timing (A)	7	
DTE Transmit Signal Element Timing (B)	14	14
Signal Ground	8	8

Table A-9. X.21 Connector Pin Assignments, 26-pin D, Male to 15-pin Female

Signal	26-pin Connector	15-pin Connector	Signal
Signal Ground	8	8	Signal Ground
Transmit (A)	2	4	Receive (A)
Transmit (B)	9	11	Receive (B)
Receive (A)	4	2	Transmit (A)
Transmit Signal Element Timing (A)	7	6	Signal Element Timing (A)
Transmit Signal Element Timing	14	13	Signal Element Timing
Signal Element Timing	1	1	Shield
Jumper	3,5		
Jumper	10,12		
		3,5	Jumper
		10,12	Jumper

---

## Appendix B. Common Tasks

This appendix provides a series of questions and answers dealing with common IBM 2216 installation, operation, and maintenance tasks, with suggestions as to where to find further help in performing them.

### LED States / Adapter Status

**Question** How do I check the states of the adapters in my IBM 2216?

**Answer** The correct LED states are displayed in the *Hardware Installation Guide*. Also, the *Maintenance Guide* treats problem determination in more detail.

### The Firmware Interface

**Question** What is the firmware interface? How do I access it?

**Answer** The firmware is the microcode lying underneath the operational code running on the 2216. It is used primarily by service personnel in problem determination. The firmware is accessed by booting the IBM 2216 and stopping the boot process with the **F1** key. It displays a menu with a number of options. Briefly, you should have a VT220 terminal with the following settings: 19.2 Kbps, 8-N-1. You can use a null modem cable for local access or a modem attachment for remote access.

Refer to the chapter entitled "Accessing the IBM 2216" in the *2216 Maintenance Guide* for more information.

### Command Line Interface

**Question** How do I access the command line interface (the operating code)?

From within the **firmware menu system** ("System Management Services"):

Press **F9**. The \* prompt is displayed after the system boots.

The command line interface is described in the *Multiprotocol Access Services Software User's Guide*.

### Displaying List of Active Interfaces

**Question** How do I display a list of active interfaces?

**Answer**

- 1** Access the command line interface (the \* prompt).
- 2** Type **talk 6** and press **Enter** twice to reach the Config> prompt.
- 3** Enter **list dev**.
- 4** Press **Ctrl-p** to return to the command line interface.

## Displaying the Operational State of the Interfaces

**Question** How do you see the state (up, down, disabled, etc.) of an interface?

**Answer**

- 1** Access the command line interface (the \* prompt).
- 2** Type **talk 5** and press **Enter** twice to reach the + (monitoring) prompt.
- 3** Enter **configuration**.
- 4** Press **Ctrl-p** to return to the command line interface.

## Verifying Connectivity

**Question** How do I verify that a given IP address is online?

**Answer**

- 1** Access the command line interface (the \* prompt).
- 2** Type **talk 5** and press **Enter** twice to reach the + prompt.
- 3** Type **protocol** and press **Enter**.
- 4** Type **ip** and press **Enter**. The prompt changes to IP>.
- 5** Type **ping IP address value** and press **Enter**. Press **Enter** to stop the ping process.
- 6** Type **exit** at the IP> prompt and press **Enter**. The prompt changes to +.
- 7** Press **Ctrl-p** to return to the command line interface.

## Viewing Vital Software Data

**Question** How do I view vital software data?

**Answer**

- 1** At the \* prompt, type **talk 6** and press **Enter** twice. The Config> prompt appears.
- 2** Enter **boot**.
- 3** Enter **describe**. The vital software data is displayed.
- 4** Press **Ctrl-p** to return to the command line interface.

## Viewing Vital Hardware Data

**Question** How do I view vital hardware data?

**Answer**

- 1** Access the firmware main menu: During boot-up, press **F1** at the Prematurely terminate boot sequence prompt.
- 2** Select **4. Utilities**.
- 3** Select **9. View or Set Vital Product Data**.
- 4** Select **Hardware Vital Product Data**. The vital hardware data is displayed.
- 5** Return to the firmware main menu.
- 6** Press **F9** to load the operating software.

## Adding an Adapter at Initial Configuration

**Question** How do I add an adapter when the IBM 2216 is being initially configured?

**Answer** First, perform hardware installation of the adapter as described in the chapter entitled “IBM 2216 FRU Exchange” in the *IBM 2216 Maintenance Guide*. Then:

- 1** Access the command line interface (\* prompt).
- 2** Type **talk 6** and press **Enter** twice to reach the Config> prompt.
- 3** Enter **add device** *type of device*.  
For example, **add device x21**
- 4** Enter the device slot number (1–8).
- 5** If you are adding an interface on a single-port adapter, go to step 6. Otherwise, continue with this step. Enter the port number (0–7, depending on the type of adapter).

The range of port numbers supported depends on the multi-port adapter type:

- For the Token-Ring (FC 2280) and Ethernet (FC 2281) adapters, port numbers 1 and 2 are supported.
- For the 8-port EIA-232E/V.24 (FC 2282) and 8-port X.21 adapters, port numbers 0–7 are supported.
- For the 6-port V.35/V.36 (FC 2290) adapter, port numbers 0–5 are supported.

- 6** Make a note of the interface number to which this port is assigned and the net number.

Repeat steps 3 to 6 if you have a multi-port adapter and you want to have more than one interface defined on that adapter.

**Note:** The steps only create the interface. You still have to use the **net** command to configure characteristics unique to that interface (e.g. T/R, Ethernet, PPP, FR, SDLC, X.25, etc.). You also need to use the **protocol** command to configure protocols on the interface.

## Adding an Adapter after Initial Configuration

**Question** How do I add an adapter after the IBM 2216 has been initially configured?

**Answer** First, perform hardware installation of the adapter as described in the chapter entitled “IBM 2216 FRU Exchange” in the *IBM 2216 Maintenance Guide*. Then:

- 1** Access the command line interface (\* prompt).
- 2** Type **talk 6** and press **Enter** twice to reach the Config> prompt.
- 3** Enter **add device** *type of device*.

For example, **add device x21**

The following two steps do not apply when a dial-circuit device is being added.

- 4** Enter the device slot number (1–8).
- 5** If you are adding an interface on a single-port adapter, go to step 6. Otherwise, continue with this step. Enter the port number (0–7, depending on the type of adapter).

The range of port numbers supported depends on the multi-port adapter type:

- For the Token-Ring (FC 2280) and Ethernet (FC 2281) adapters, port numbers 1 and 2 are supported.
- For the 8-port EIA-232E/V.24 (FC 2282) and 8-port X.21 adapters, port numbers 0–7 are supported.
- For the 6-port V.35/V.36 (FC 2290) adapter, port numbers 0–5 are supported.

- 6** Make a note of the interface number to which this port is assigned and the net number.
- 7** Enter **net** *net number* to enable you to configure interface-unique characteristics.
- 8** Enter **write** to save your changes.
- 9** Reboot the IBM 2216 to make the configuration changes active.

For details of this procedure, refer to the *Multiprotocol Access Services Software User's Guide*.

## Running Quick Configuration

**Question** How do I run the Quick Configuration program?

**Answer** First, make sure each adapter has been “added” (see “Adding an Adapter at Initial Configuration”). Then, at the Config (only) prompt, enter **qc**.

## Disabling an Adapter Port

**Question** How do I disable a configured adapter port?

**Answer**

- 1** Access the command line interface (\* prompt).
- 2** Type **talk 6** and press **Enter** twice to reach the Config> prompt.
- 3** Enter **list device**.
- 4** Make a note of the interface number of the adapter you wish to disable.
- 5** Enter **disable interface** *interface number*.
- 6** Enter **write** to save your changes.
- 7** Reboot the IBM 2216 to make the configuration changes active.

For details of this procedure, refer to the *Multiprotocol Access Services Software User's Guide*.

## Enabling an Adapter Port

**Question** How do I enable a configured adapter port that was disabled using **disable interface** (in “Disabling an Adapter Port”)?

Use this procedure to enable the port the next time that you reboot the 2216.

**Answer**

- 1** Access the command line interface (\* prompt).
- 2** Type **talk 6** and press **Enter** twice to reach the Config> prompt.
- 3** Enter **list device**.
- 4** Make a note of the interface number of the adapter you wish to enable.
- 5** Enter **enable interface** *interface number*.
- 6** Enter **write** to save your changes.
- 7** Reboot the IBM 2216 to make the configuration changes active.

For details of this procedure, refer to the *Multiprotocol Access Services Software User's Guide*.

## Disabling an Adapter Port to Suspend Traffic

**Question** How do I disable a configured adapter port to remove or test an adapter?

### Answer

- 1** Access the command line interface (\* prompt).
- 2** Type **talk 5** and press **Enter** twice to reach the + prompt.
- 3** Enter the **configuration** command.
- 4** Make a note of the interface number of the adapter that you want to disable.
- 5** Enter **disable** *interface number*.

## Enabling an Adapter Port to Resume Traffic

**Question** How do I enable a configured adapter port (that was disabled using the **talk 5 disable** command in “Disabling an Adapter Port to Suspend Traffic”) to resume traffic?

### Answer

- 1** Access the command line interface (\* prompt).
- 2** Type **talk 5** and press **Enter** twice to reach the + prompt.
- 3** Enter the **configuration** command.
- 4** Make a note of the interface number of the adapter you wish to enable.
- 5** Enter **test** *interface number*.

**Note:** If you use the **test** command to enable an interface that has been configured (in **talk 6**) as disabled, the next time that you reboot the 2216 the interface will be disabled again.

Therefore, you should also use the **talk 6 enable interface** command to ensure that the interface is enabled the next time a reboot does occur.

For details of this procedure, refer to the *Multiprotocol Access Services Software User's Guide*.



## Removing and Deleting an Adapter

**Question** How do I remove and delete an adapter from the configuration?

**Answer**

- 1** Access the command line interface (\* prompt).
- 2** Type **talk 6** and press **Enter** twice to reach the Config> prompt.
- 3** Enter **list device**.
- 4** On a sheet of paper, write down the interface number of the adapter you wish to delete.  
**Note:** If you are removing a multi-port adapter, then you need to record the interface number of all interfaces configured for that adapter.
- 5** Enter **delete interface** *interface number*.
- 6** At the Are you sure? prompt, enter **y**.
- 7** Enter **write** to save your changes.
- 8** Reboot the IBM 2216 to make the configuration changes active.

For details of this procedure, refer to the *Multiprotocol Access Services Software User's Guide*.

## Running Diagnostics

**Question** How are diagnostics run on a particular adapter?

**Answer** Refer to the *IBM 2216 Maintenance Guide*.

## Up-to-Date IBM 2216 Information

**Question** How can I find out the most current information about the IBM 2216?

**Answer** Point your web browser to  
<http://www.networking.ibm.com/216/216prod.html>

## Disabling Interfaces that have WAN Reroute Enabled

**Question** How do I ensure that WAN Reroute does not try to automatically enable an alternate interface that is on an adapter about to be removed?

### Answer

- 1** Access the command line interface (the \* prompt).
- 2** Type **talk 5**, and press **Enter** twice to reach the + (monitoring) prompt.
- 3** Type **feature wrs** to get to the WRS> prompt.
- 4** At the WRS> prompt, type **list alternate-circuit**.
- 5** If any of the alternate circuits are interfaces on the adapter that is about to be removed:  
Disable WAN Reroute/WAN Restoral altogether. Type **disable wrs**.  
*or*  
Disable WAN Reroute on an individual interface basis. Type **disable alternate-circuit**.
- 6** After WAN Reroute is disabled, go back to the + prompt by typing **exit**.
- 7** Type **disable slot** or the **disable interface#** for each interface on the adapter.

## Enable WAN Reroute after you have Disabled it

**Question** How do I enable WAN Reroute to automatically enable an alternate interface that is on an adapter that has be replaced?

### Answer

- 1** Access the command line interface (the \* prompt).
- 2** Type **talk 5** and press **Enter** twice to reach the + (monitoring) prompt.
- 3** Type **feature wrs** to get to the WRS> prompt.
- 4** If you disabled WAN Restoral/WAN Reroute altogether, type **enable wrs** to re-enable it.  
If you had just disabled an individual alternate-circuit, type **enable alternate-circuit** to re-enable the WAN Reroute's use of that alternate circuit.
- 5** After WAN Reroute is disabled, go back to the + prompt by typing **exit**.

**6** Type **enable slot** to start a self-test for each interface on the adapter *or* type **test interface#** for each interface that you want to bring up.

If you start a self-test for an alternate interface and the self-test is successful, the alternate interface will remain up even though it may not be needed to back-up a primary interface. If this happens, you can issue the talk 5 **disable interface#** command to put the alternate interface back into the standby (disabled) state.



---

## Appendix C. Charts and Worksheets

This appendix contains a number of planning worksheets that will help you to get your IBM 2216 operational and ready to perform any necessary configuration. The worksheets are:

- Rack Inventory Chart
- Quick Configuration Worksheet
- Initial Configuration Worksheet
- Token-Ring Configuration Worksheet
- LLC Configuration Worksheet

# Rack Inventory Chart for the 2216

Date

Wiring Closet Number  Rack Number  Planner's Initials

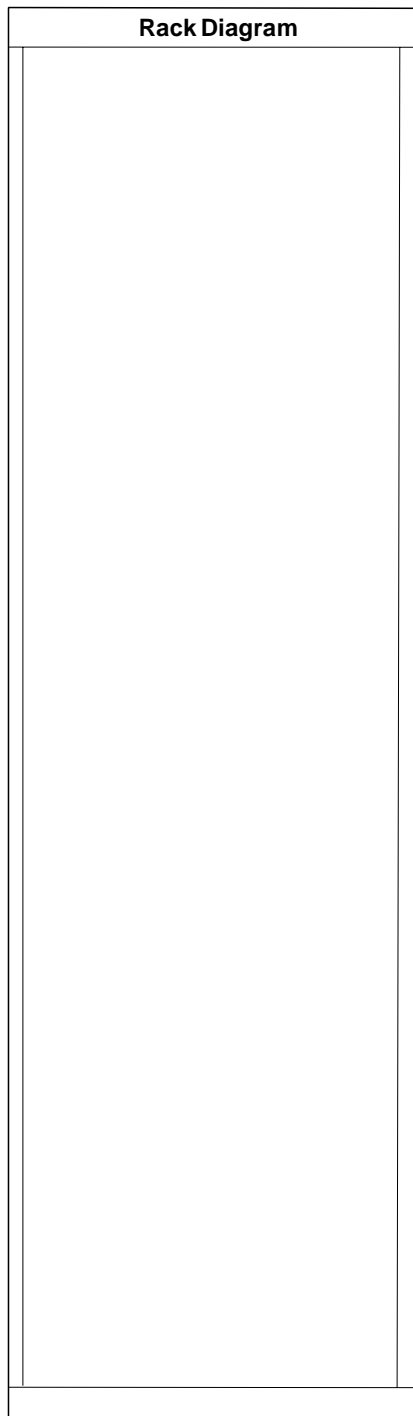

## Instructions

Fill out a Rack Inventory Chart for each equipment rack.

1. Enter the wiring closet location number, the equipment rack identification number, and the planner's initials.
2. Use the dimensions below to represent the size of the 2216.
3. Write the unit identification number and component type on each component on the chart.

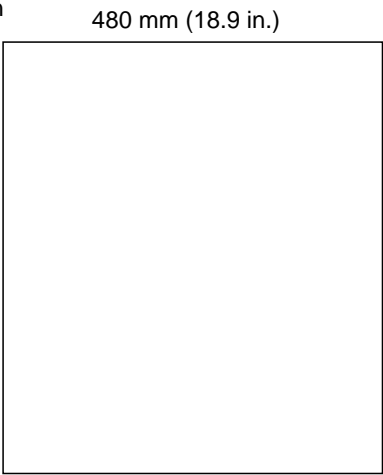

## Example

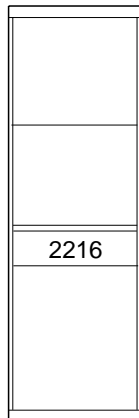

2216 Dimensions Scaled to the size of the Rack Diagram



## IPX

Configure **IPX**?  YES  NO

Configure Interface \_\_\_  YES  NO  
(0-xx)?

Configure IPX on this inter-  YES  NO  
face?

**Token Ring** encapsulation (*frame*) type?

TOKEN—RING MSB †

TOKEN—RING LSB

TOKEN—RING\_SNAP MSB

TOKEN—RING\_SNAP LSB

**Ethernet** encapsulation (*frame*) type?

ETHERNET\_8022

ETHERNET\_8023

ETHERNET\_ii

ETHERNET\_SNAP

Network No. (1-FFFFFFFE)

Enable IPXWAN? \_\_\_\_\_  YES  NO

Host No. for Serial Lines \_\_\_\_\_

Configure IPXWAN  YES  NO  
Nodeid?

Nodeid (1-FFFFFFFE)  1 †  Other \_\_\_\_\_

**Save this configuration?**  YES  NO



## DNA (DECNet)

Configure <b>DNA</b> ?	<input type="checkbox"/> YES	<input type="checkbox"/> NO	
Highest Node No. (1–1023)	<input type="checkbox"/> 32 †	<input type="checkbox"/> Other	_____
Router Level	<input type="checkbox"/> Proteon Level1 †	<input type="checkbox"/> Proteon Level2	<input type="checkbox"/> DEC Level1 <input type="checkbox"/> DEC Level2
Highest Area (1–63)	<input type="checkbox"/> 63 †	<input type="checkbox"/> Other	_____
Node address	_____	Address Mask	_____
Configure DNA on Interface ___?	<input type="checkbox"/> YES	<input type="checkbox"/> NO	
Max Routers (1–33)?	<input type="checkbox"/> 16 †	<input type="checkbox"/> Other	_____
<b>Save this configuration?</b>	<input type="checkbox"/> YES	<input type="checkbox"/> NO	

**Note:** † = default

# Initial Configuration Worksheet

Table C-1. Initial Configuration Worksheet

<input type="checkbox"/> Add	<input type="checkbox"/> Device	<input type="checkbox"/> Token-Ring  <input type="checkbox"/> Ethernet  <input type="checkbox"/> ATM  <input type="checkbox"/> ISDN (T1/J1)  <input type="checkbox"/> ISDN (E1)  <input type="checkbox"/> X.21  <input type="checkbox"/> V.35/V.36  <input type="checkbox"/> EIA-232E/V.24  <input type="checkbox"/> Dial Circuits	Slot #: _____ Port #: _____  Slot #: _____ Port #: _____  Slot #: _____  Slot #: _____  Slot #: _____ Port #: _____  Slot #: _____ Port #: _____  Slot #: _____ Port #: _____  Slot #: _____ Port #: _____
------------------------------	---------------------------------	--	--

# Token-Ring Configuration Worksheet

Accept all defaults

*Table C-2. Token-Ring Configuration Worksheet*

<input type="checkbox"/> Frame	<input type="checkbox"/> Token-Ring  <input type="checkbox"/> Token-Ring_SNAP	<input type="checkbox"/> MSB <input type="checkbox"/> LSB  <input type="checkbox"/> MSB <input type="checkbox"/> LSB
<input type="checkbox"/> Media	<input type="checkbox"/> Shielded † <input type="checkbox"/> Unshielded	
<input type="checkbox"/> Packet-Size	<input type="checkbox"/> 4 Mbps  <input type="checkbox"/> 16 Mbps	<input type="checkbox"/> 2052 † <input type="checkbox"/> 4399  <input type="checkbox"/> 1470 <input type="checkbox"/> 2052 <input type="checkbox"/> 4399 <input type="checkbox"/> 8130 <input type="checkbox"/> 11407 <input type="checkbox"/> 17749
<input type="checkbox"/> Set	<input type="checkbox"/> Physical-address  <input type="checkbox"/> RIF-Timer	<input type="checkbox"/> _____  <input type="checkbox"/> 120 † <input type="checkbox"/> _____
<input type="checkbox"/> Source-Routing	<input type="checkbox"/> Enable † <input type="checkbox"/> Disable	
<input type="checkbox"/> Speed	<input type="checkbox"/> 4 Mbps † <input type="checkbox"/> _____	
<input type="checkbox"/> LLC Config	<input type="checkbox"/> Yes <input type="checkbox"/> No	

# LLC Configuration Worksheet

Accept all defaults

*Table C-3. LLC Configuration Worksheet*

<input type="checkbox"/> Set	<input type="checkbox"/> n2-max-retry	<input type="checkbox"/> max-retry value	<input type="checkbox"/> 8 † <input type="checkbox"/> _____
	<input type="checkbox"/> n3-frames_rcvd-before-ack	<input type="checkbox"/> Number I-frames received before sending Ack	<input type="checkbox"/> 1 † <input type="checkbox"/> _____
	<input type="checkbox"/> rw-receive-window	<input type="checkbox"/> Receive window	<input type="checkbox"/> 2 † <input type="checkbox"/> _____
	<input type="checkbox"/> t1-reply-timer	<input type="checkbox"/> Reply timer	<input type="checkbox"/> 1 † <input type="checkbox"/> _____
	<input type="checkbox"/> t2-receive-ack-timer	<input type="checkbox"/> Receive Ack timer	<input type="checkbox"/> 1 † <input type="checkbox"/> _____
	<input type="checkbox"/> ti-inactivity-timer	<input type="checkbox"/> Inactivity timer	<input type="checkbox"/> 30 † <input type="checkbox"/> _____
	<input type="checkbox"/> tw-transmit window	<input type="checkbox"/> Transmit window	<input type="checkbox"/> 2 † <input type="checkbox"/> _____
	<input type="checkbox"/> nw-acks-to-inc-ww	<input type="checkbox"/> Acks needed to increment Ww	<input type="checkbox"/> 1 † <input type="checkbox"/> _____

---

## Appendix D. Factory Plugging Defaults

Units assembled at the factory follow the plugging rules that are described in this appendix.

---

### Assumptions

- No more than six of any combination of Token-Ring (FC 2280) and Ethernet (FC 2281) adapters will be installed.
- If a combination of **six** 2280 and 2281 adapters is to be installed, no other adapters will be installed.
- If a combination of **five** 2280 and 2281 adapters is to be installed, then two additional adapters can also be installed.
- A maximum of **four** ISDN adapters (2283 or 2292) can be installed.
- A maximum of **two** ATM adapters (2284 and 2293) can be installed.

---

### Plugging Sequences

Table D-1 illustrates how the slots are numbered: two rows of four slots, numbered 1 through 8:

Slot 1	Slot 2	Slot 3	Slot 4
Slot 5	Slot 6	Slot 7	Slot 8

These tables show the default sequence of installation for the various adapters.

FC 2280 and FC 2281 are installed left to right, beginning with slot 1. A maximum of six can be installed in any single IBM 2216.

1	3	5	
2	4	6	

Other adapters are installed right-to-left in the first-available slot beginning with slot 8 on the bottom and far right.

8	6	4	3
7	5	2	1



---

## Appendix E. Management of Routing Networks

Experience has shown that networks employing routing have certain characteristics and requirements in common. The information in this appendix has been gathered over time through experience with such networks and is offered as a general guide to their management.

This appendix describes the management of routing networks and covers the following topics:

- Network characteristics
- Basic principles
- The network organization
- Configuration management
- Router changes (configuration and hardware)
- Network changes

---

### Network Characteristics

The routing network includes many components and has the following characteristics:

- The network is an open system.
- There are many similar but different components.
- Each configuration file must complement many others.
- Many different approaches can be used.
- Each configuration file contains many parameters (1300+ available).
- Many failures are dependent on specific application loads.
- Some configuration errors appear to be box problems.
- One configuration error can bring down the network.

The network is a complex system that must be managed. There are:

- Many interdependencies
- Few absolutes

---

### Basic Principles

#### Configuration Control

Configuration control requires a consistent approach that is best achieved by one person, referred to in this appendix as the *Network Engineer*, or by a unified team. This person or team should work in conjunction with a central control point, referred to as the *Network Management Center (NMC)*.

#### The Network Engineer

To ensure consistency throughout the network, a single individual or a unified team must establish an approach and define or approve the configuration for each network box. Routing networks are defined by a large number of parameters specified in a number of different network boxes. The parameters specified in the different boxes must complement each other to form a unified and functioning network. The configuration program specifies these network parameters for the IBM 2216.

There is no “right” set of parameters and box configurations for a network. There are many possible configuration combinations.

### **Central Control Point (Network Management Center)**

All configurations and updates should be loaded and updated from a central control point, usually the Network Management Center (NMC). This allows a single individual (or team) to monitor, test, and coordinate activities at several locations or sites from a single location. This is easily accomplished using TCP/IP Telnet methods in combination with the remote access features in the IBM routers.

An exception to loading all configurations directly from a central control point is the initial configuration for a new router or the reconnection of a router to the network following a repair or hardware change. However, all these configurations should be supplied by, and controlled by, the NMC.

When problems occur, all activities should be coordinated with the Network Management Center. The NMC involves the Network Support Team, network engineer, and box support/service organizations as needed.

## **Step-by-Step Configurations**

Maintain a solid base by configuring the network step-by-step. The key factors are:

- IP connectivity (direct routes only)
- One protocol at a time
- Patience

### **IP Connectivity**

Each router should be configured initially with only IP direct routes. With this configuration installed, it is easy to verify that each port on the router is connected to the device specified. Simply “ping” through the port to the attached device. If the ping is not successful, it is clear that the link being pinged has a problem. If dynamic routing protocols are active, they may route the ping around the problem, making it difficult to detect and identify the problem.

### **One Protocol at a Time**

After IP connectivity has been established, enable one protocol at a time and test each to verify the router is functioning in the network as expected. This step-by-step approach applies to application protocols such as IPX and NetBIOS as well as network protocols such as OSPF and RIP.

In established well-controlled networks where step-by-step configurations have been applied consistently without corrections, you can combine several protocols into one step. However, if you encounter problems, return to a single protocol per step until consistency is reestablished.

### **Patience**

It may take considerable time for some configurations to load and become functional, especially if the advanced network protocols such as OSPF are used in a large network. For large networks with thousands of devices, it is not unusual for this to take from 15 minutes to an hour or more.



## Configuration and Network Debugging

Reestablishes a solid base:

- Expect many types of errors.
- Limit time attempting a “quick fix.”
- Generate new configurations from scratch.

### Many Types of Errors

Errors in the configuration program can cause many different types of problems. They may initially appear to be router hardware problems because the router will not complete booting or data will not flow through an adapter port. Also, configuration errors may not cause a problem initially, but will cause a problem when specific conditions are encountered.

### Generate New Configurations

If a problem is not resolved after you make a few changes to a configuration file, it is highly recommended that you generate a new configuration file from scratch following the step-by-step approach already defined.

A few changes to the configuration will often create additional errors which compounds the problem and requires a number of hours to debug and resolve. Also, some parameters may have been activated or changed by accident. It may take over an hour to check all 1300+ parameters in the questionable configuration file. A new configuration can usually be generated and tested step-by-step within an hour. Also, there is a high probability that this new configuration will function as desired or a defect in the network configuration or the network devices will be identified.

---

## The Network Organization

The key is to have structure and control. A typical organization consists of:

- The Network Management Center (NMC)
- The Network Engineer
- The Network Support Team
- The Network Manager

**Note:** Many other structures can be used, and these functions can be combined with others.

## Network Management Center

The Network Management Center (NMC) provides network monitoring, network coordination, and network control.

### Network Monitoring

For large networks, the NMC:

- Provides support 24 hours a day, 7 days a week, with operators present. This may be combined with the Help Desk.
- Uses NV/6000 or a similar tool.
- Monitors network capacity measurements.
- Takes all calls relative to network problems.

- Maintains network diagram and associated databases.
- Maintains data and service procedures for:
  - Network external connections (T1, Frame Relay, and so on)
  - Equipment used in the network
  - Service and support organizations

For small networks, the NMC:

- Provides support 24 hours a day, 7 days a week. This function may be combined with the Network Engineer function.
- Takes or records all calls relative to network problems.
- Maintains network diagram and associated data.
- Maintains data and service procedures as needed.

## Network Coordination

The NMC:

- Calls and dispatches the Network Support Team to investigate problems. The Network Engineer or IBM systems engineering operations specialist may replace the Support Team for small networks.
- Calls suppliers and others for problem resolution.
- Negotiates network down time between network users and the problem solvers or network changers.
- Coordinates and schedules planned network down time and maintenance.
- Coordinates requests for network improvements and expansions. This activity includes:
  - Receiving requests from users and management
  - Forwarding requests to the Network Engineer
  - Informing users and requesters of planned actions
- Schedules and coordinates network changes as defined by the Network Engineer.

## Network Control

The NMC:

- Implements and documents all changes to the network. The Network Support Team or Network Engineer make the changes, but the NMC controls and documents them.
- Coordinates all maintenance, test, and diagnostics activities:
  - Before activity starts
  - After activity is complete, with results reported even if previously scheduled and on-time
- Ensures that network procedures are followed ... “network police.”
  - For problem determination, maintenance, and changes
  - Procedures provided by the Network Engineer

**Note:** The Network Engineer must also follow the procedures.
- Escalates issues to the correct person:
  - Users to area coordinator or area management

- Service providers to their management
- Network support team to the Network Engineer
- Network Engineer to the Network Manager

## Network Engineer

The Network Engineer:

- May be replaced by a team of people that functions as single unit
- May be the IBM systems engineering operations specialist for small networks
- Obtains recommendations from many sources.

The Network Engineer is responsible for:

1. Network design, function, and cost:
  - Defines or approves all network changes
  - Tracks and analyzes network performance and issues
  - Defines NMC and other procedures associated with the network
2. Network problem resolution:
  - Resolves problems reported by the NMC, management, or network users
  - Coordinates all activity through the NMC
3. Training and education:
  - NMC personnel
  - Network support team personnel
  - Network users
  - Managers, both users and network support
  - Service and other related personnel
  - New network engineers

**Note:** Other agencies may actually deliver the training.

## Network Support Team

The Network Support Team is responsible for:

1. Network maintenance and debugging:
  - Box connectivity and interface connectors, converters, and adapters
  - Workstations, servers, terminals, printers
  - Bridges, routers
  - Facilities, space, and security as required for each item.
  - Location and access to each box, cable, and set of documentation.
2. Identification and correction of problems or concerns:
  - Resolves issues directly when possible
  - Requests support from component or box supplier when needed
  - Provides Network Engineer or others with data relative to the problem or concern
  - Implements tests or corrections as defined by Network Engineer or equipment supplier
  - Keeps NMC informed of all activities and results
3. Assistance and coordination of equipment suppliers:
4. Implementation of measurements, tests, and changes according to directions provided by the Network Engineer.

## Network Manager

The Network Manager is responsible for:

1. Network management and operation:
  - Sets priorities
  - Resolves disputes
  - Ensures quality
2. Finances:
  - Funding
  - Expense Recovery
3. Staffing:
  - Obtains the skills needed
  - Deals with personnel issues and evaluations
  - Responsible for organization and controls
4. Interfacing to the organization and users:
  - Ensures continued funding
  - Identifies changes in requirements
5. Supporting the “network police”

---

## Configuration Management

Configuration management involves:

- Configurations
- Configuration sets
- Naming conventions
- Router configuration changes
- Hardware changes that affect the network
- Hardware changes that do not affect the network
- Router code updates

## Configurations

These are maintained:

1. On the Configuration Workstation in the NMC for each router:
  - An IP direct route only configuration to verify router connectivity
  - A complete protocol configuration based on current functions
  - Individual protocol test configurations
  - A history of previous configurations

Different configuration files must be clearly labeled or named.

2. At each router:
  - PC terminal emulator and IP direct route diskettes
  - or
  - Data and instructions for configuring an IP direct route plus ASCII terminal, cables, and so on.

Alternatively, a telephone line and modem can be connected to a service port and the NMC can install configuration files as needed.

3. On additional configuration workstations or files:

- Backup files are needed for NMC configuration workstation
- Multi-configuration workstations may be needed for large or geographically dispersed networks, but must be closely coordinated and controlled.

## Configuration Sets

Configuration sets are maintained in configuration database (CDB) files created by configuration programs.

Different configuration sets can be maintained for:

- Current network operations (production)
- Previously-used CDBs
- Special applications or events
- Tests for special functions, performance, and so on
- Planned improvements and expansions

## Naming Conventions

### Concepts

Name each configuration file so that it can be quickly and directly identified relative to:

- Router
- Configuration type (IP only, IP routing protocols, and so on)
- Configuration set

A naming convention may be required to use special programs for configuration set transfer and import.

### Configuration Database Names

The following example is an approach used for AIX workstations. It uses an 8-character name with the following format:

xxxxxxxx.CDB

Examples:

CURPROD_.CDB	Current production configuration set
CURIPDIR.CDB	Current IP Direct Route configuration set
H930814_.CDB	History production configuration from 8/14/93
E1103TST.CDB	Enhancement configuration set tested 11/03
BLDAPPN_.CDB	Building configuration set for APPN.

## Configuration File Names

An approach used for AIX workstations:

```
xxxxxxx-Rrrrr111bbb-nnnnnn
   |      |      |      |
   8      1      4      7      1      6      27 Characters Displayed
   |      |      |      |
   |      |      |      |----- Application Information
   |      |      |      |----- Location & Building
   |      |      |      |----- Router Number
   |      |      |      |----- Configuration Set Name
```

Examples of CDB files:

```
CURPROD_-R0023ALT0063-ENG
CURPROD_-R0102NYC953K-ACTPAY
CURPROD_-R1031RAL016A-DIVHQ
CURPROD_-R0527TKO_ASC-MFG001
```

:

```
CURIPDIR-R0023ALT0063-ENG
CURIPDIR-R0102NYC953K-ACTPAY
CURIPDIR-R1031RAL016A-DIVHQ
CURIPDIR-R0527TKO_ASC-MFG001
```

Examples of router directory (*names*)

```
CURPROD_-R0023ALT0063-ENG
CURIPDIR-R0023ALT0063-ENG
H930814_-R0023ALT0063-ENG
E1103TST-R0023ALT0063-ENG
BLDAPPN_-R0023ALT0063-ENG
```

## Router Configuration Changes

Router configuration changes include:

- Adjustment of cost factors, filters, etc.
- Adjustment of data collection or tracking
- Addition of protocol features
- Adjustment for a network addition

Make configuration changes as follows:

1. The Network Engineer defines or approves all changes, specifying the time and/or prerequisites for implementation:
  - Schedule for non-critical or off-shift periods
  - Stable network defined as no problems within xx hours
2. All changes include a description of:
  - The expected events during the configuration change
  - The expected results or impact on the router and network
3. All changes include a “bail-out” plan:
  - How to keep the network operational if problems develop
  - When to implement the plan
4. The NMC applies configuration changes:
  - Established procedures are followed.
  - Changes and results are documented.

- Network engineer and others may observe or assist.

**Note:** If problems are encountered, obtain assistance from:

- The Network Support Specialist
- The Network Engineer
- The IBM 2216 Level II Support

---

## Changes to a Router

Changes to a router include hardware changes that do or do not affect the network, and router code updates.

## Hardware Changes that Affect the Network

These changes include:

- Adapter, port, or interface cable changes
- Connection of a new router into the network
- System board replacement

Make hardware changes that affect the network as follows:

1. The Network Engineer defines or approves all network changes, including:
  - Change instructions
  - Time and prerequisites for changes
  - Results and impact of changes
  - A “bail-out” plan, and when to implement it
2. The NMC schedules all changes to the network.
3. The service representative contacts the NMC and verifies planned activities, including the “bail-out” plan.
4. The service representative implements the hardware changes and runs diagnostics as needed.
5. The NMC and service representative verify that:
  - Cables are connected to the ports according to the configuration.
  - The operating system level and Configuration Program are compatible.
6. The service representative connects the router to the network by configuring an IP direct route to the network using the instructions and data provided.
7. The NMC completes the IP direct route configuration.
8. The NMC verifies network connectivity by testing connectivity to and from each attached port using the network diagram and change instructions.
9. The NMC installs IP routing protocol configurations and verifies them.

**Note:** The service representative may leave the site at this point.
10. The NMC installs application protocol configurations and verifies them.
11. The NMC documents the changes and their impact, and monitors function for a significant time.

## Hardware Changes that Do Not Affect the Network

These changes include, for example, replacement of a fan or power supply in a router that was functioning in the network prior to the hardware problem. Hardware changes that do not affect the network are made as follows:

1. The NMC schedules all changes to the network.
2. The service representative contacts the NMC and verifies planned activities:
  - “Bail-out” plan
  - Availability of hardware and configuration files
3. The service representative implements the hardware changes and runs diagnostics as needed.
4. The service representative informs the NMC that the router is ready for network reconnection.
5. The service representative connects the router to the network by plugging in the power cord and verifying that the system and ports are active without errors.
6. The NMC verifies that the router is functioning as before.
7. The NMC documents the changes.

## Router Code Updates

Update the router code as follows:

1. The Network Engineer defines or approves all network changes. The definition includes:
  - Update instructions
  - Time and prerequisites for update
  - Results and impact of update
  - A “Bail-out” plan, and when to implement it
2. The NMC loads PTFs to the router. If the update cannot be installed remotely by the NMC, the NMC controls the activity at the router.
3. If the current configuration is not compatible with updated router level:
  - Update the configuration files using the configuration program:
    - IP direct route only configuration
    - Functional configuration with all protocols
    - Test configurations such as IP routing protocol
  - Load configurations into the router
  - Update local configuration data sources (verify that instructions and data for configuring IP direct routes are available).
4. Commit PTFs according to instructions. The router reboots with the current configuration.
5. The NMC verifies that the router is functioning according to the update instructions and previous data, documents the update and results, and monitors function for a significant time.
6. New functional configurations are generated and installed by the NMC. After the network is verified as stable at new code level, configurations are changed to use the new capability.



---

## Network Changes

### Configuration Build Sequence

Use the following configuration build sequence:

1. Generate router configurations. A typical sequence is:
  - a. IP direct routes
  - b. IP routing protocols
  - c. IP filter and exports
  - d. Application 1 protocol
  - ⋮
  - e. Application  $n$  protocol
2. Test and/or analyze:
  - a. Test bed with load/traffic
  - or
  - Network engineer with direct experience
  - b. Non-critical subnets or segments
    - Implement according to procedure (NMC)
    - Operate for significant time
    - Do three segments without errors or problems
3. Schedule remaining subnets or segments:
  - The NMC implements the changes.
  - When problems occur, drop back to the test bed.

### Network Configuration Changes

Update the router code as follows:

1. The Network Engineer defines or approves each configuration.
  - Configurations are named according to established conventions.
  - Each configuration set is in the CDB file by router type.
  - Configuration change instructions are available.
  - A “bail-out” plan is available.
2. The NMC transfers configuration files to the routers.
3. Import the configuration for each router. This requires a defined plan, including router sequence, to:
  - Maintain connectivity
  - Minimize exposure to significant network down time:
    - One router or subset at a time
    - One router every xxx minutes
    - All routers at same time
4. Monitor the network to verify the changes.
5. Document configuration changes and effects.

## Network Code Updates

Apply network code updates as follows:

1. Test and/or analyze:
  - a. Test bed with load/traffic  
or  
Network engineer with direct experience
  - b. Non-critical subnet or segment
    - Implement according to procedure (NMC)
    - Operate for significant time
    - Do three segments without errors or problems
  - c. You may use special features or shell scripts:
    - To transmit PTFs to all routers
    - To apply and commit either one at a time (sequence important) or all at once.
2. Schedule remaining subnets or segments:
  - The NMC implements the changes.
  - When problems occur, drop back to the test bed.
3. Stabilize at single code level (single configuration level).

## Network Expansion Example

This example involves connecting additional LANs and WANs to the network.

Assumptions:

- This is a tested and established procedure.
- NMC personnel are experienced.
- This is a large network with hundreds of routers.

### 1. Preparation by the NMC

1. Network Change Instructions are available and approved.
2. The NMC verifies that:
  - Telco links are active between routers  $l_i$  and  $N_i$ .
  - Telco links are connected to correct ports in  $l_i$ .
  - The LAN connections are available and active for  $N_i$ .
  - The new routers ( $N_i$ ) are at the site.
3. The NMC schedules the service representative or network support specialists for each site. Each service representative or support specialist has:
  - A plan and procedures to be used, including information about what to use when.
  - Documentation needed:
    - Phone number for NMC
    - Network diagram and/or data needed
    - Installation and other procedures
    - Port locations
    - Physical location data

- Equipment needed
  - IP direct route Configuration Diskette
  - Diagnostics diskettes
  - Modem and associated cables
  - Terminal and associated cables

**Note:** Some or all of these items may be available at the site.

## 2. Key Installation Steps

1. Each service representative (or support specialist) contacts the NMC from the site and verifies the plan.
2. Each service representative sets up the router at the site:
  - Verifies that ports are as specified
  - Runs diagnostics if required
  - Positions router in specified location
  - Connects network cables as specified
3. The NMC installs expansion configurations in the interface routers:
  - Previous functional configurations with new connections added.
  - They may be installed in advance or during previous change.
4. The service representative contacts the NMC to coordinate the connection of the router (Ni) to the network, and then:
  - Plugs in the power cord with the terminal connected.
  - Configures an IP direct route to the network according to the instructions and data provided.
5. The NMC completes the direct route configuration.
6. The NMC verifies connectivity for router (Ni):
  - Tests connectivity to and from each attached port.
  - Tests using network diagram and change instructions.
7. The NMC multiplexes with all sites to verify connectivity. Problems are debugged and resolved if possible. If problems are not resolved:
  - Expansion proceeds using the connections available.
  - Allowable delays are defined by change instructions.
  - Service call is initiated to resolve the problem.
8. The NMC installs IP Routing Protocols on each router:
  - Transfers and commits configurations for each router.
  - Tests to verify IP routing for the expanded network:
    - using the Network Change Instructions
    - Checking routing tables, processes running, and so on.

**Note:** The service representative may leave the site when IP routing is verified.
9. The NMC installs application protocols on each router, transfers and commits configurations for each router, and tests to verify that the expanded network is functioning.
10. The NMC documents the expansion and the effect, continues to monitor function for a significant time, and schedules further expansions when stability is verified.

### 3. Network Roll-Out Plan

This plan summarizes the activities and costs for the network expansion example.

#### **NMC operator (1/2 day):**

Adds two to six routers to the network (number dependent on complexity).

Schedules future expansion project:

- Service representative and Telco activity
- Network cable availability

#### **Configuration specialist (1/2 day):**

Generates configuration files needed for project (most configurations are generated in advance).

Generates new configurations as needed to:

- Debug or verify a problem
- Correct identified problems

#### **Service representative for each router:**

Requires 2 to 5 person-hours per site (each router is at a different site).

#### **NMC user interface specialists (1/2 day x 2 specialists):**

- Coordinate new function or change with user groups.
- Prepares users for the change.
- Schedules the change.
- Handles questions and problems.

#### **Roll-out rate and costs:**

Based on 16 to 48 routers per week:

8 half-days for adding routers

2 half-days for follow-up problems

Four NMC personnel:

1 Operator

1 Configuration specialist

2 User interface specialists

#### **Total roll-out costs per router:**

3 to 10 NMC hours per router

2 to 5 service representative (or network specialist) hours per router

## Network Expansion Requirements

This section summarizes the network expansion requirements in terms of personnel experience and network controls that must be in place.

### **1. Experienced Network Installer/Designer**

- More than four networks designed, each supported for more than one year
- Hands-on full-time support for a time on each network

### **2. Experienced Network Installer for the NMC**

- More than 4 years hands-on full-time installation and maintenance
- Four different network types including network expansions
- Can quickly generate network diagram from routing tables
- Can recognize symptoms from many different types of problems

### 3. Network Controls in Place and Working

- Approval of all network changes by the Network Engineer
- Coordination of all network support activity through the NMC
- Network police active and backed by network management
- Documented procedures and controls with flowcharts

### 4. Local Network Support

- Support personnel with quick access to each node
- Can set up, test, and repair routers and related products
- Can assist network installer and the Network Engineer

## Network Configuration Changes

Make network configuration changes as follows:

1. The Network Engineer defines or approves each configuration.
  - Configurations are named according to established conventions.
  - Each configuration set is in the CDB file by router type.
  - Configuration change instructions are available.
  - A “bail-out” plan is available.
2. The NMC transfers configurations to the routers.
3. Import configuration for each router using the special program.
4. Import the configuration for each router using the special program. This requires a defined plan, including router sequence, to:
  - Maintain connectivity
  - Minimize exposure to significant network down time:
    - One router or subset at a time
    - One router every xxx minutes
    - All routers at same time
5. Monitor the network to verify the changes:
  - Observe router status changing as configurations take effect.
  - Check routing tables and other parameters.
  - Check compliance with configuration change instructions.
6. The NMC documents the changes and their impact, and monitors function for a significant time.



---

## Appendix F. Notices

References in this publication to IBM products, programs, or services do not imply that IBM intends to make these available in all countries in which IBM operates. Any reference to an IBM product, program, or service is not intended to state or imply that only IBM's product, program, or service may be used. Subject to IBM's valid intellectual property, or other legally protectable rights, any functionally equivalent product, program, or service that does not infringe any of IBM's intellectual property rights may be used instead of the IBM product, program, or service. The evaluation and verification of operation in conjunction with other products, except those expressly designated by IBM, are the user's responsibility.

IBM may have patents or pending patent applications covering subject matter in this document. The furnishing of this document does not give you any license to these patents. You can send license inquiries, in writing, to:

IBM Director of Licensing  
IBM Corporation  
500 Columbus Avenue  
Thornwood, NY 10594 USA

---

## Electronic Emission Notices

### Federal Communications Commission (FCC) Statement

**Note:** This equipment has been tested and found to comply with the limits for a Class A digital device, pursuant to Part 15 of the FCC Rules. These limits are designed to provide reasonable protection against harmful interference when the equipment is operated in a commercial environment. This equipment generates, uses, and can radiate radio frequency energy and, if not installed and used in accordance with the instruction manual, may cause harmful interference to radio communications. Operation of this equipment in a residential area is likely to cause harmful interference, in which case the user will be required to correct the interference at his own expense.

Properly shielded and grounded cables and connectors must be used in order to meet FCC emission limits. IBM is not responsible for any radio or television interference caused by using other than recommended cables and connectors or by unauthorized changes or modifications to this equipment. Unauthorized changes or modifications could void the user's authority to operate the equipment.

This device complies with Part 15 of the FCC Rules. Operation is subject to the following two conditions: (1) this device may not cause harmful interference, and (2) this device must accept any interference received, including interference that may cause undesired operation.

## FCC Part 68 Compliance Information:

Features and optional adapters for the IBM 2216 comply with Part 68 of the FCC rules. The label included on the adapter tray contains, among other information, the FCC registration number and Ringer Equivalence Number (REN), if applicable for this equipment. If requested, provide this information to your telephone company.

The features and adapters included are:

Feature Code	Part Name
<b>2283</b>	1-Port ISDN PRI (T1/J1) Adapter LIC 283 with interface code 04DU9-1SN, service code 6.0N and jack type RJ48C.

The REN is useful to determine the quantity of devices you may connect to your telephone line and still have those devices ring when your number is called. In most, but not all areas, the sum of the RENs of all devices should not exceed five (5.0). To be certain of the number of devices you may connect to your line, as determined by the REN, you should call your local telephone company to determine the maximum REN for your calling area.

If the IBM 2216 causes harm to the telephone network, the Telephone Company may discontinue your service temporarily. If possible, they will notify you in advance. But if advance notice isn't practical, you will be notified as soon as possible. You will be advised of your right to file a complaint with the FCC.

Your telephone company may make changes in its facilities, equipment, operations, or procedures that could affect the proper operation of your equipment. If they do, you will be given advance notice so as to give you an opportunity to maintain uninterrupted service.

If trouble is experienced with this equipment, for repair or warranty information, in the United States, call IBM at **1-800-IBM-SERV**. In Canada, call IBM at **1-800-465-6600**.

No repairs can be performed by the customer.

## Industry Canada Compliance Statement

This digital apparatus does not exceed the Class A limits for radio noise emissions from digital apparatus as set out in the interference-causing equipment standard entitled: *Digital Apparatus*, ICES-003 of Industry Canada.

## Avis de conformité aux normes d'Industrie Canada

Cet appareil numérique respecte les limites de bruits radioélectriques applicables aux appareils numériques de Classe A prescrites dans la norme sur le matériel brouiller: *Appareils numériques*, NMB-003 édictée par Industrie Canada.

## Industry Canada Information:

NOTICE: The Industry Canada label identifies certified equipment. This certification means that the equipment meets certain telecommunications network protective,



operational and safety requirements. Industry Canada does not guarantee the equipment will operate to the user's satisfaction.

Before installing this equipment, users should ensure that it is permissible to be connected to the facilities of the local telecommunications company. The equipment must also be installed using an acceptable method of connection. In some cases, the company's inside wiring associated with a single line individual service may be extended by means of a certified connector assembly (telephone extension cord). The customer should be aware that compliance with the above conditions may not prevent degradation of service in some situations.

Repairs to certified equipment should be made by an authorized Canadian maintenance facility designated by the supplier. Any repairs or alterations made by the user to this equipment, or equipment malfunctions, may give the telecommunications company cause to request the user to disconnect the equipment.

Users should ensure for their own protection that the electrical ground connections of the power utility, telephone lines and internal metallic water pipe system, if present, are connected together. This precaution may be particularly important in rural areas.

**CAUTION:** Users should not attempt to make such connections themselves, but should contact the appropriate electrical inspection authority, or electrician, as appropriate.

**AVIS :** L'étiquette d'Industrie Canada permet d'identifier un équipement homologué. Cette homologation signifie que cet équipement satisfait certaines exigences en matière de protection, d'exploitation et de sécurité du réseau de télécommunications. Industrie Canada n'offre aucune garantie que le fonctionnement de cet équipement soit à la satisfaction de l'utilisateur.

Avant d'installer cet équipement, l'utilisateur doit s'assurer qu'il a la permission de le raccorder aux installations de l'entreprise de télécommunications. L'installation de cet équipement doit aussi se faire selon un mode de raccordement acceptable. Dans certains cas, le câblage interne de l'entreprise associé au service individuel offert par une ligne d'abonné peut être prolongé au moyen d'un connecteur homologué (prolongateur de téléphone). Le client devrait être informé que la conformité de son équipement aux conditions susmentionnées n'est pas une prévention contre la dégradation du service dans certaines situations.

Toute réparation d'un équipement homologué devrait être effectuée par un service de maintenance canadien autorisé qui a été désigné par le fournisseur. Toute réparation ou modification d'équipement faite par l'utilisateur, ou tout mauvais fonctionnement, pourrait entraîner la déconnexion de cet équipement par l'utilisateur à la demande de l'entreprise de télécommunications.

Pour sa protection personnelle, l'utilisateur devrait s'assurer que les mises à la terre des services publics électriques, des lignes téléphoniques et du système interne des canalisations d'eau à tuyaux métalliques, advenant leur présence, sont interconnectées. Dans les zones rurales, il s'agit-là d'une précaution particulièrement importante à prendre.

**ATTENTION :** Toute tentative de connexion par l'utilisateur est à déconseiller. Il est préférable de communiquer avec le responsable de l'inspection en électricité ou un électricien, selon le cas.

## European Community (EC) Mark of Conformity Statement

This product is in conformity with the protection requirements of EC Council Directive 89/336/EEC on the approximation of the laws of the Member States relating to electromagnetic compatibility. IBM cannot accept responsibility for any failure to satisfy the protection requirements resulting from a non-recommended modification of the product, including the fitting of non-IBM option cards.

A typical host which conforms to the protection requirements of EC Council Directive 89/336/EEC on the approximation of the law of the Member States relating to electromagnetic compatibility will continue to conform when this product is installed and operated in it.

Operation of this product in a domestic/residential environment may cause radio interference, which the user may be required to take measures to suppress.

A Declaration of Conformity with the requirements of the Directive has been signed by IBM Spain, Division of Fabricacion, 46185 La Pobla de Vallbona, Valencia, Spain.

The product bears the Telecom CE mark (CE 168 X) for ISDN Basic Rate complying with I-CTR3 (Bridging measures) as per the European directive 91/263/EEC (TTE directive). The product bears the Telecom CE mark (CE 168 X) for: V.24/V.28,V36 and X.21 electrical interfaces complying with NET 1 and with NET 2 physical level. ISDN Basic Rate complying with I-CTR3 (Bridging measures) as per the European directive 91/263/EEC (TTE directive).

This product has been tested and found to comply with the limits for Class B Information Technology Equipment according to CISPR 22 / European Standard EN 55022. The limits for Class B equipment were derived for typical residential environments to provide reasonable protection against interference with licensed communication devices.

Dieses Gerät ist berechtigt in Übereinstimmung mit dem deutschen EMVG vom 9.Nov.92 das EG-Konformitätszeichen zu führen. Der Außsteller der Konformitätserklärung ist die IBM Spain, Division of Fabricacion, 46185 La Pobla de Vallbona, Valencia, Spain.

Dieses Gerät erfüllt die Bedingungen der EN 55022 Klasse B.

## Japanese Voluntary Control Council for Interference (VCCI) Statement

This equipment is Class 1 Equipment (information equipment to be used in commercial and industrial districts) which is in conformance with the standard set by the Voluntary Control for Interference Council by Data Processing Equipment and Electronic Office Machines (VCCI) with an aim to prevent radio interference in commercial and industrial districts. This equipment could cause interference to radio and television receivers when used in and around residential districts. Please handle the equipment properly according to the instruction manual.

## 情報処理装置等電波障害自主規制協議会 (VCCI) 表示

この装置は、第一種情報装置(商工業地域において使用されるべき情報装置)で商工業地域での電波障害防止を目的とした情報処理装置等電波障害自主規制協議会(VCCI)基準に適合しております。

従って、住宅地域またはその隣接した地域で使用すると、ラジオ、テレビジョン受信機等に受信障害を与えることがあります。

取扱説明書に従って正しい取り扱いをして下さい。

## Korean Communications Statement

Please note that this device has been approved for business purpose with regard to electromagnetic interference. If you find this is not suitable for your use, you may exchange it for a non-business purpose one.

대한민국 통신문

이 기기는 업무용으로 전자장해능정을 받은 기기이오니 구매자 또는 사용자는 이 점을 주의하시기 바라며, 만약 잘못 구입하였을 때에는 구입한 곳에서 비업무용으로 교환하시기 바랍니다.

---

## Trademarks

The following terms, denoted by an asterisk (\*), used in this publication, are trademarks or service marks of IBM Corporation in the United States or other countries:

IBM	Nways	OS/2
AT	XGA	NetView
RETAIN	Presentation Manager	AIXwindows
RS/6000	PS/2	OS/2
Personal System/2	Operating System/2	

Microsoft, Windows, and the Windows 95 logo are trademarks or registered trademarks of Microsoft Corporation.

Other company, product, and service names, which may be denoted by a double asterisk (\*\*), may be trademarks or service marks of others.



---

# Glossary

This glossary includes terms and definitions from:

- The *IBM Dictionary of Computing* (New York; McGraw-Hill, Inc., 1994).
- The *American National Standard Dictionary for Information Systems*, ANSI X3.172-1990, copyright 1990 by the American National Standards Institute (ANSI). Copies may be purchased from the American National Standards Institute, 11 West 42nd Street, New York, New York 10036. Definitions are identified by the symbol (A) after the definition.
- The *Information Technology Vocabulary*, developed by Subcommittee 1, Joint Technical Committee 1, of the International Organization for Standardization and the International Electrotechnical Commission (ISO/IEC JTC1/SC1). Definitions of published parts of this vocabulary are identified by the symbol (I) after the definition; definitions taken from draft international standards, committee drafts, and working papers being developed by ISO/IEC JTC1/SC1 are identified by the symbol (T) after the definition, indicating that final agreement has not yet been reached among the participating National Bodies of SC1.
- The Network Working Group Request for Comments: 1208.

The following cross-references are used in this glossary:

**Contrast with:** This refers to a term that has an opposed or substantively different meaning.

**Synonym for:** This indicates that the term has the same meaning as a preferred term, which is defined in its proper place in the glossary.

**Synonymous with:** This is a backward reference from a defined term to all other terms that have the same meaning.

**See:** This refers the reader to multiple-word terms that have the same last word.

**See also:** This refers the reader to terms that have a related, but not synonymous, meaning.

## A

**A.** Ampere.

**active.** (1) Operational. (2) Pertaining to a node or device that is connected or is available for connection to another node or device.

**Advanced Peer-to-Peer Networking (APPN) network node.** A node that offers a broad range of end-user services and that can provide the following:

- Distributed directory services, including registration of its domain resources to a central directory server
- Topology database exchanges with other APPN network nodes, enabling network nodes throughout the network to select optimal routes for LU-LU sessions based on requested classes of service
- Session services for its local LUs and client end nodes
- Intermediate routing services within an APPN network

**agent.** A system that assumes an agent role.

**analog.** (1) Pertaining to data consisting of continuously variable physical quantities. (A) (2) Contrast with *digital*.

**AppleTalk.** A network protocol developed by Apple Computer, Inc. This protocol is used to interconnect network devices, which can be a mixture of Apple and non-Apple products.

**APPN node.** Advanced Peer-to-Peer Networking (APPN) node.

**attachment unit interface (AUI).** In a local area network, the interface between the medium attachment unit and the data terminal equipment within a data station. (I) (A)

**AUI.** Attachment unit interface.

**autonomous system (AS).** A group of networks and routers that use the same interior gateway protocol and for which one administrative authority has responsibility.

## B

**bps.** Bits per second.

**bridge.** A functional unit that interconnects multiple LANs (locally or remotely) that use the same logical link control protocol but that can use different medium access control protocols. A bridge forwards a frame to another bridge based on the medium access control (MAC) address.

**bridging.** In LANs, the forwarding of a frame from one LAN segment to another. The destination is specified by the medium access control (MAC) sublayer address

encoded in the destination address field of the frame header.

## C

**CCITT.** International Telegraph and Telephone Consultative Committee. This was an organization of the International Telecommunication Union (ITU). On 1 March 1993 the ITU was reorganized, and responsibilities for standardization were placed in a subordinate organization named the Telecommunication Standardization Sector of the International Telecommunication Union (ITU-TS). "CCITT" continues to be used for recommendations that were approved before the reorganization.

**circuit.** (1) One or more conductors through which an electric current can flow. See *physical circuit* and *virtual circuit*. (2) A logic device.

**circuit switching.** (1) A process that, on demand, connects two or more data terminal equipment (DTEs) and permits the exclusive use of a data circuit between them until the connection is released. (I) (A) (2) Synonymous with *line switching*.

**configuration.** (1) The manner in which the hardware and software of an information processing system are organized and interconnected. (T) (2) The devices and programs that make up a system, subsystem, or network.

**connection.** In data communication, an association established between functional units for conveying information. (I) (A)

## D

**data circuit.** (1) A pair of associated transmit and receive channels that provide a means of two-way data communication. (I) (2) See also *physical circuit* and *virtual circuit*.

### Notes:

1. Between data switching exchanges, the data circuit may include data circuit-terminating equipment (DCE), depending on the type of interface used at the data switching exchange.
2. Between a data station and a data switching exchange or data concentrator, the data circuit includes the data circuit-terminating equipment at the data station end, and may include equipment similar to a DCE at the data switching exchange or data concentrator location.

**data circuit-terminating equipment (DCE).** In a data station, the equipment that provides the signal conversion and coding between the data terminal equipment (DTE) and the line. (I)

### Notes:

1. The DCE may be separate equipment or an integral part of the DTE or of the intermediate equipment.
2. A DCE may perform other functions that are usually performed at the network end of the line.

**data link control (DLC).** A set of rules used by nodes on a data link (such as an SDLC link or a token ring) to accomplish an orderly exchange of information.

**data link switching (DLSw).** A method of transporting network protocols that use IEEE 802.2 logical link control (LLC) type 2. SNA and NetBIOS are examples of protocols that use LLC type 2. See also *encapsulation* and *spoofing*.

**data link switching (DLSw).** A method of transporting network protocols that use Institute of Electrical and Electronics Engineers (IEEE) 802.2 logical link control (LLC) type 2. Systems Network Architecture (SNA) and NetBIOS are examples of protocols that use LLC type 2.

**data terminal equipment (DTE).** That part of a data station that serves as a data source, data sink, or both. (I) (A)

**data terminal ready (DTR).** A signal to the modem used with the EIA 232 protocol.

**DCE.** Data circuit-terminating equipment.

**dependent LU requester (DLUR).** An APPN end node or an APPN network node that owns dependent LUs, but requests that a dependent LU server provide the SSCP services for those dependent LUs.

**device.** A mechanical, electrical, or electronic contrivance with a specific purpose.

**digital.** (1) Pertaining to data that consist of digits. (T) (2) Pertaining to data in the form of digits. (A) (3) Contrast with *analog*.

**DLS.** Data link switching.

**DLUR.** Dependent Logical Unit Requester.

**DLUR.** Dependent LU requester.

**DTE.** Data terminal equipment. (A)

## E

**EIA.** Electronic Industries Association.

**EIA unit.** A unit of measure, established by the Electronic Industries Association, equal to 44.45 millimeters (1.75 inches).

**EIA 232.** In data communications, a specification of the Electronic Industries Association (EIA) that defines the interface between data terminal equipment (DTE) and data circuit-terminating equipment (DCE), using serial binary data interchange.

**Electronic Industries Association (EIA).** An organization of electronics manufacturers that advances the technological growth of the industry, represents the views of its members, and develops industry standards.

**encapsulation.** In communications, a technique used by layered protocols by which a layer adds control information to the protocol data unit (PDU) from the layer it supports. In this respect, the layer encapsulates the data from the supported layer. In the Internet suite of protocols, for example, a packet would contain control information from the physical layer, followed by control information from the network layer, followed by the application protocol data. See also *data link switching (DLSw)*.

**Ethernet.** A 10-Mbps baseband local area network that allows multiple stations to access the transmission medium at will without prior coordination, avoids contention by using carrier sense and deference, and resolves contention by using collision detection and transmission. Ethernet uses carrier sense multiple access with collision detection (CSMA/CD).

## F

**flash memory.** A data storage device that is programmable, erasable, and does not require continuous power. The chief benefit of flash memory over other programmable and erasable data storage devices is that it can be reprogrammed without being removed from the circuit board.

**frame relay.** (1) An interface standard describing the boundary between a user's equipment and a fast-packet network. In frame-relay systems, flawed frames are discarded; recovery comes end-to-end rather than hop-by-hop. (2) A technique derived from the integrated services digital network (ISDN) D channel standard. It assumes that connections are reliable and dispenses with the overhead of error detection and control within the network.

**frequency.** The rate of signal oscillation, expressed in hertz.

## G

**gateway.** (1) A functional unit that interconnects two computer networks with different network architectures. A gateway connects networks or systems of different architectures. A bridge interconnects networks or systems with the same or similar architectures. (T) (2) In the IBM Token-Ring Network, a device and its associated software that connect a local area network to another local area network or a host that uses different logical link protocols.

## H

**high-performance file system (HPFS).** In the OS/2 operating system, an installable file system that uses high-speed buffer storage, known as a cache, to provide fast access to large disk volumes. The file system also supports the coexistence of multiple, active file systems on a single personal computer, with the capability of multiple and different storage devices. File names used with the HPFS can have as many as 254 characters.

**high-performance routing (HPR).** An addition to the Advanced Peer-to-Peer Networking (APPN) architecture that enhances data routing performance and reliability, especially when using high-speed links.

## I

**IEEE.** Institute of Electrical and Electronics Engineers.

**impedance.** The combined effect of resistance, inductance, and capacitance on a signal at a given frequency.

**integrated services digital network (ISDN).** A digital end-to-end telecommunication network that supports multiple services including, but not limited to, voice and data.

**Note:** ISDNs are used in public and private network architectures.

**interface.** (1) A shared boundary between two functional units, defined by functional characteristics, signal characteristics, or other characteristics, as appropriate. The concept includes the specification of the connection of two devices having different functions. (T) (2) Hardware, software, or both, that links systems, programs, or devices.

**International Organization for Standardization (ISO).** An organization of national standards bodies from various countries established to promote development of standards to facilitate international exchange of

goods and services, and develop cooperation in intellectual, scientific, technological, and economic activity.

**Internet.** A worldwide network connecting users through autonomous networks in industry, education, government, and research. The Internet network uses Internet Protocol (IP). The major Internet services include electronic mail, FTP, telnet, World Wide Web, and electronic bulletin boards (Usenet). For network interconnection and routing, and Transmission Control Protocol (TCP) for end-to-end control. (A)

**internet.** A collection of networks interconnected by a set of routers that allow them to function as a single, large network. See also *Internet*.

**Internet Protocol (IP).** A connectionless protocol that routes data through a network or interconnected networks. IP acts as an intermediary between the higher protocol layers and the physical network. However, this protocol does not provide error recovery and flow control and does not guarantee the reliability of the physical network.

**Internetwork Packet Exchange (IPX).** The network protocol used to connect Novell's servers, or any workstation or router that implements IPX, with other workstations. Although similar to the Internet Protocol (IP), IPX uses different packet formats and terminology.

**IP.** Internet Protocol.

**IPX.** Internetwork Packet Exchange.

**ISDN.** Integrated services digital network.

**ISO.** International Organization for Standardization.

## K

**kVA.** kilovolt amperes.

## L

**LAN.** Local area network.

**line switching.** Synonym for *circuit switching*.

**link.** The combination of the link connection (the transmission medium) and two link stations, one at each end of the link connection. A link connection can be shared among multiple links in a multipoint or token-ring configuration.

**link connection.** The physical equipment providing two-way communication between one link station and one or more other link stations; for example, a telecommunication line and data circuit-terminating equipment (DCE). Synonymous with *data circuit*.

**local.** Pertaining to a device accessed directly without use of a telecommunication line.

**local area network (LAN).** (1) A computer network located on a user's premises within a limited geographical area. Communication within a local area network is not subject to external regulations; however, communication across the LAN boundary may be subject to some form of regulation. (T) (2) A network in which a set of devices are connected to one another for communication and that can be connected to a larger network. See also *Ethernet* and *token ring*. (3) Contrast with *metropolitan area network (MAN)* and *wide area network (WAN)*.

## M

**MAN.** Metropolitan area network.

**Management Information Base (MIB).** (1) A collection of objects that can be accessed by means of a network management protocol. (2) A definition for management information that specifies the information available from a host or gateway and the operations allowed. (3) In OSI, the conceptual repository of management information within an open system.

**metropolitan area network (MAN).** A network formed by the interconnection of two or more networks which may operate at higher speed than those networks, may cross administrative boundaries, and may use multiple access methods. (T) Contrast with *local area network (LAN)* and *wide area network (WAN)*.

**MIB.** (1) MIB module. (2) Management Information Base.

**modem (modulator/demodulator).** (1) A functional unit that modulates and demodulates signals. One of the functions of a modem is to enable digital data to be transmitted over analog transmission facilities. (T) (A) (2) A device that converts digital data from a computer to an analog signal that can be transmitted on a telecommunication line, and converts the analog signal received to data for the computer.

## N

**network.** (1) A configuration of data processing devices and software connected for information interchange. (2) A group of nodes and the links interconnecting them.

**network architecture.** The logical structure and operating principles of a computer network. (T)

**Note:** The operating principles of a network include those of services, functions, and protocols.



**network management.** The process of planning, organizing, and controlling a communication-oriented data processing or information system.

## P

**packet mode operation.** Synonym for *packet switching*.

**packet switching.** (1) The process of routing and transferring data by means of addressed packets so that a channel is occupied only during transmission of a packet. On completion of the transmission, the channel is made available for transfer of other packets. (1) (2) Synonymous with *packet mode operation*. See also *circuit switching*.

**physical circuit.** A circuit established without multiplexing. See also *data circuit*. Contrast with *virtual circuit*.

**Point-to-Point Protocol (PPP).** A protocol that provides a method for encapsulating and transmitting packets over serial point-to-point links.

**port.** (1) An access point for data entry or exit. (2) A connector on a device to which cables for other devices such as display stations and printers are attached. Synonymous with *socket*. (3) The representation of a physical connection to the link hardware. A port is sometimes referred to as an adapter; however, there can be more than one port on an adapter. There may be one or more ports controlled by a single DLC process. (4) In the Internet suite of protocols, a 16-bit number used to communicate between TCP or the User Datagram Protocol (UDP) and a higher-level protocol or application. Some protocols, such as File Transfer Protocol (FTP) and Simple Mail Transfer Protocol (SMTP), use the same well-known port number in all TCP/IP implementations. (5) An abstraction used by transport protocols to distinguish among multiple destinations within a host machine.

**PPP.** Point-to-Point Protocol.

**problem determination.** The process of determining the source of a problem; for example, a program component, machine failure, telecommunication facilities, user or contractor-installed programs or equipment, environmental failure such as a power loss, or user error.

## R

**ring.** See *ring network*.

**ring network.** (1) A network in which every node has exactly two branches connected to it and in which there are exactly two paths between any two nodes. (T) (2) A network configuration in which devices are connected by unidirectional transmission links to form a closed path.

**route.** (1) An ordered sequence of nodes and transmission groups (TGs) that represent a path from an origin node to a destination node traversed by the traffic exchanged between them. (2) The path that network traffic uses to get from source to destination.

**router.** (1) A computer that determines the path of network traffic flow. The path selection is made from several paths based on information obtained from specific protocols, algorithms that attempt to identify the shortest or best path, and other criteria such as metrics or protocol-specific destination addresses. (2) An attaching device that connects two LAN segments, which use similar or different architectures, at the reference model network layer. Contrast with *bridge* and *gateway*. (3) In OSI terminology, a function that determines a path by which an entity can be reached.

**routing.** (1) The assignment of the path by which a message is to reach its destination. (2) In SNA, the forwarding of a message unit along a particular path through a network, as determined by parameters carried in the message unit, such as the destination network address in a transmission header.

## S

**SDLC.** Synchronous Data Link Control.

**Serial Line Internet Protocol (SLIP).** A TCP/IP protocol used on a point-to-point connection between two IP hosts over a serial line (for example, an RS/EIA-232 connection into a modem over a telephone line).

In an NBBS network, the SLIP is used over a connection between an Nways Switch administration station (NAS) and an IBM Network Support Center (NSC).

**Simple Network Management Protocol (SNMP).** In the Internet suite of protocols, a network management protocol that is used to monitor routers and attached networks. SNMP is an application layer protocol. Infor-

mation on devices managed is defined and stored in the application's Management Information Base (MIB).

**SLIP.** Serial Line Internet Protocol.

**SNA.** Systems Network Architecture.

**SNMP.** Simple Network Management Protocol.

**socket.** The abstraction provided by the University of California's Berkeley Software Distribution (commonly called Berkeley UNIX or BSD UNIX) that serves as an endpoint for communication between processes or applications.

**source route bridging.** In LANs, a bridging method that uses the routing information field in the IEEE 802.5 medium access control (MAC) header of a frame to determine which rings or token-ring segments the frame must transit. The routing information field is inserted into the MAC header by the source node. The information in the routing information field is derived from explorer packets generated by the source host.

**spoofing.** For data links, a technique in which a protocol initiated from an end station is acknowledged and processed by an intermediate node on behalf of the final destination. In IBM 6611 data link switching, for example, SNA frames are encapsulated into TCP/IP packets for transport across a non-SNA wide area network, unpacked by another IBM 6611, and passed to the final destination. A benefit of spoofing is the prevention of end-to-end session timeouts.

**synchronous.** (1) Pertaining to two or more processes that depend upon the occurrence of specific events such as common timing signals. (T) (2) Occurring with a regular or predictable time relationship.

**Synchronous Data Link Control (SDLC).** A discipline conforming to subsets of the Advanced Data Communication Control Procedures (ADCCP) of the American National Standards Institute (ANSI) and High-level Data Link Control (HDLC) of the International Organization for Standardization, for managing synchronous, code-transparent, serial-by-bit information transfer over a link connection. Transmission exchanges may be duplex or half-duplex over switched or nonswitched links. The configuration of the link connection may be point-to-point, multipoint, or loop. (I) Contrast with *binary synchronous communication (BSC)*.

**synchronous optical network (SONET).** A US standard for transmitting digital information over optical interfaces. It is closely related to the synchronous digital hierarchy (SDH) recommendation.

**system.** In data processing, a collection of people, machines, and methods organized to accomplish a set of specific functions. (I) (A)

**Systems Network Architecture (SNA).** The description of the logical structure, formats, protocols, and operational sequences for transmitting information units through, and controlling the configuration and operation of, networks. The layered structure of SNA allows the ultimate origins and destinations of information, that is, the end users, to be independent of and unaffected by the specific SNA network services and facilities used for information exchange.

## T

**TCP.** Transmission Control Protocol.

**TCP/IP.** Transmission Control Protocol/Internet Protocol.

**TN3270.** An informally defined protocol for transmitting 3270 data streams over Telnet.

**TN3270.** An informally defined protocol for transmitting 3270 data streams over Telnet.

**token.** (1) In a local area network, the symbol of authority passed successively from one data station to another to indicate the station temporarily in control of the transmission medium. Each data station has an opportunity to acquire and use the token to control the medium. A token is a particular message or bit pattern that signifies permission to transmit. (T) (2) In LANs, a sequence of bits passed from one device to another along the transmission medium. When the token has data appended to it, it becomes a frame.

**token ring.** (1) According to IEEE 802.5, network technology that controls media access by passing a token (special packet or frame) between media-attached stations. (2) A FDDI or IEEE 802.5 network with a ring topology that passes tokens from one attaching ring station (node) to another. (3) See also *local area network (LAN)*.

**Transmission Control Protocol (TCP).** A communications protocol used in Internet and in any network that follows the U.S. Department of Defense standards for internetwork protocol. TCP provides a reliable host-to-host protocol between hosts in packet-switched communications networks and in interconnected systems of such networks. It assumes that the Internet protocol is the underlying protocol.

**Transmission Control Protocol/Internet Protocol (TCP/IP).** A set of communications protocols that support peer-to-peer connectivity functions for both local and wide area networks.

**transparent bridging.** In LANs, a method for tying individual local area networks together through the medium access control (MAC) level. A transparent bridge stores the tables that contain MAC addresses so

that frames seen by the bridge can be forwarded to another LAN if the tables indicate to do so.

**Trivial File Transfer Protocol (TFTP).** In the Internet suite of protocols, a protocol for file transfer that requires minimal overhead and minimal capability. TFTP uses the connectionless datagram delivery services of the User Datagram Protocol (UDP), which allows hosts that have no disk storage to implement TFTP in read-only memory (ROM) and use it to boot themselves.

## U

**UTP.** Unshielded twisted pair.

## V

**V.24.** In data communications, a specification of the CCITT that defines the list of definitions for interchange circuits between data terminal equipment (DTE) and data circuit-terminating equipment (DCE).

**V.25.** In data communications, a specification of the CCITT that defines the automatic answering equipment and parallel automatic calling equipment on the General Switched Telephone Network, including procedures for disabling of echo controlled devices for both manually and automatically established calls.

**V.35.** In data communications, a specification of the CCITT that defines the list of definitions for interchange circuits between data terminal equipment (DTE) and data circuit-terminating equipment (DCE) at various data rates.

**V.36.** In data communications, a specification of the CCITT that defines the list of definitions for interchange circuits between data terminal equipment (DTE) and data circuit-terminating equipment (DCE) at rates of 48, 56, 64, or 72 kilobits per second.

**Vac.** Volts alternating current.

**version.** A separately licensed program that usually has significant new code or new function.

**virtual circuit.** (1) In packet switching, the facilities provided by a network that give the appearance to the user of an actual connection. (T) See also *data circuit*. Contrast with *physical circuit*. (2) A logical connection established between two DTEs.

## W

**WAN.** Wide area network.

**wide area network (WAN).** (1) A network that provides communication services to a geographic area larger than that served by a local area network or a metropolitan area network, and that may use or provide public communication facilities. (T) (2) A data communications network designed to serve an area of hundreds or thousands of miles; for example, public and private packet-switching networks, and national telephone networks. Contrast with *local area network (LAN)* and *metropolitan area network (MAN)*.

## X

**X.21.** An International Telegraph and Telephone Consultative Committee (CCITT) recommendation for a general-purpose interface between data terminal equipment and data circuit-terminating equipment for synchronous operations on a public data network.

**X.25.** An International Telegraph and Telephone Consultative Committee (CCITT) recommendation for the interface between data terminal equipment and packet-switched data networks. See also *packet switching*.



---

# Index

## A

- access methods, physical 3-1
- access to the IBM 2216 3-6
- accessing the IBM 2216 3-1
- active file status 3-10
- ASCII terminal 3-3
- attributes 3-3
- avail file status 3-10

## B

- bank for operational software images 3-10
- boot config, TFTP file transfer in 3-8
- boot configuration commands 3-9
- bridging, configuring using quick configuration 5-2
- broken file status 3-10

## C

- cable specifications
  - EIA 232-E/V.24 A-3
  - service port A-1
  - V.35 A-4
  - V.36 A-6, A-7
  - X.21 A-8
  - X.21 direct connect A-8
- change management 3-7, 3-9
- command line interface 3-6
- config as seen in change management 3-10
- configuration and monitoring tools 3-4
- configuring 5-7
- configuring DECnet 5-9
- configuring IP 5-5
- copy command in change management 3-16

## D

- DECnet, configuring 5-9
- describe config images 3-15
- describe load images 3-15
- disable dumping 3-15
- downloading files to the IBM 2216 3-9
- dumping, disabling 3-15
- dumping, enabling 3-15

## E

- EIA 232E/V.24 cable specifications A-3
- ELS 3-6
- enable dumping 3-15
- Ethernet
  - encapsulation types for IPX 5-8

- event logging system (ELS) 3-6

## F

- file statuses 3-10
- file transfer 3-7
- file transfer using TFTP or Xmodem 3-8

## G

- GWCON 3-6

## H

- hardware of the IBM 2216 3-6
- hardware requirements 2-12

## I

- image of the operational software 3-10
- IP (Internet Protocol), configuring using quick configuration 5-5
- IP, configuring 5-5
- IPX (Internetwork Packet Exchange)
  - configuring using quick configuration 5-7
  - Ethernet encapsulation types 5-8
  - token ring encapsulation types 5-7
- IPX, configuring 5-7

## L

- local file status 3-10

## M

- managing software files 3-9
- microcode 3-9
- modem, PCMCIA 3-7
- monitoring and configuration tools 3-4
- monitoring process for the command line (GWCON) 3-6

## N

- networks supported 2-1

## O

- OPCON 3-6
- operator control module (OPCON) 3-6
- other change management functions 3-15

## **P**

- PCMCIA modem 3-7
- pending file status 3-10
- physical access methods 3-1
- physical characteristics of the IBM 2216 2-9
- protocols
  - configuring using quick configuration 5-4
- protocols supported 2-2

## **Q**

- quick configuration
  - bridging configuration 5-2
  - protocol configuration
    - IP user interface 5-5
    - IPX user interface 5-7
  - procedure 5-4
- quick configuration sample 5-2

## **R**

- rack-shelf placement 2-8
- reload 3-10
- resetting the IBM 2216 3-10
- restart 3-10
- restarting the IBM 2216 5-11
- router, restarting 5-11

## **S**

- sample, quick configuration 5-2
- sending configuration files from the Configuration Program 3-11
- service port cable specifications A-1
- set active configuration 3-13
- set active load image 3-13
- set boot list 3-13
- set commands for change management 3-12
- set serial port 3-14
- settings, ASCII terminal 3-3
- setup attributes, ASCII terminal 3-3
- software 3-9
- software and configuration change management 3-7

## **T**

- tabletop placement 2-8
- talk 5 3-6
- talk 6 3-6
- terminal settings 3-3
- terminal, ASCII 3-3
- TFTP for file transfer 3-8
- token ring
  - encapsulation types for IPX 5-7
- tools
  - configuration and monitoring 3-4

## **V**

- V.35 cable specifications A-4
- V.36 cable specifications A-6, A-7

## **X**

- X.21 cable specifications A-8
  - direct connect A-8
- Xmodem for file transfer 3-8

---

# Tell Us What You Think!

## 2216 Nways Multiaccess Connector Planning and Setup Guide

Publication No. GA27-4105-00

We hope you find this publication useful, readable, and technically accurate, but only you can tell us! Your comments and suggestions will help us improve our technical publications. Please take a few minutes to let us know what you think by completing this form. If you are in the U.S.A., you can mail this form postage free or fax it to us at 1-800-253-3520. Elsewhere, your local IBM branch office or representative will forward your comments or you may mail them directly to us.

Overall, how satisfied are you with the information in this book?	Satisfied	Dissatisfied
	<input type="checkbox"/>	<input type="checkbox"/>

How satisfied are you that the information in this book is:	Satisfied	Dissatisfied
Accurate	<input type="checkbox"/>	<input type="checkbox"/>
Complete	<input type="checkbox"/>	<input type="checkbox"/>
Easy to find	<input type="checkbox"/>	<input type="checkbox"/>
Easy to understand	<input type="checkbox"/>	<input type="checkbox"/>
Well organized	<input type="checkbox"/>	<input type="checkbox"/>
Applicable to your task	<input type="checkbox"/>	<input type="checkbox"/>

Specific comments or problems:

---

---

---

Please tell us how we can improve this book:

---

---

---

Thank you for your comments. If you would like a reply, provide the necessary information below.

\_\_\_\_\_  
Name

\_\_\_\_\_  
Address

\_\_\_\_\_  
Company or Organization

\_\_\_\_\_

\_\_\_\_\_  
Phone No.

\_\_\_\_\_



Fold and Tape

Please do not staple

Fold and Tape



NO POSTAGE  
NECESSARY  
IF MAILED IN THE  
UNITED STATES

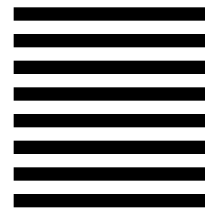

# BUSINESS REPLY MAIL

FIRST-CLASS MAIL PERMIT NO. 40 ARMONK, NEW YORK

POSTAGE WILL BE PAID BY ADDRESSEE

Design & Information Development  
Dept. CGF/Bldg. 656  
International Business Machines Corporation  
PO BOX 12195  
RESEARCH TRIANGLE PARK NC 27709-9990



Fold and Tape

Please do not staple

Fold and Tape







Part Number: 38H7824

Printed in U.S.A.

